4600 Series Tape Subsystem

**Product Description
Manual**

EO 051 0

March 1985

Storage Technology Corporation



4600 Series Tape Subsystem

**Product Description
Manual**

EO 051 0

March 1985

4600 Series Tape Subsystem

**Product Description
Manual**

EO 051 0

March 1985

Storage Technology Corporation

Information contained in this publication is subject to change. In the event of changes, the publication will be revised. Comments or questions concerning this manual should be directed to Product Marketing at the following address. A prepaid Readers' Comment Form is provided at the back of the manual.

This publication was prepared by Storage Technology Corporation, Product Marketing, MD 3K, 2270 South 88th Street, Louisville, Colorado 80028.

Copyright © 1985
by
Storage Technology Corporation
All Rights Reserved

LIST OF EFFECTIVE PAGES

Manual PN EO 051 0

Issue Date: August 1983
Reissue Date: March 1985
Change Date:

Total number of pages in this document is 78, consisting of the following pages:

PAGE	CHANGE NO.	DISPOSITION
Title		
ii thru xiv		
1-1 thru 1-10		
2-1 thru 2-8		
3-1 thru 3-12		
4-1 thru 4-18		
5-1 thru 5-2		
6-1 thru 6-6		
A-1 thru A-6		
Index 1 thru 2		
Reader's Comment Form		
Business Reply Mailer		

(INTENTIONALLY LEFT BLANK)

INTRODUCTION

SCOPE

This document contains a description of the Storage Technology Corporation Model 4600 Tape Subsystem. The material in this document is intended for the use of Storage Technology Corporation marketing representatives, customers, independent consultants, and service representatives.

MANUAL ORGANIZATION

Chapter 1 - PRODUCT DESCRIPTION: Presents the Storage Technology Corporation Model 4600 Tape Subsystem and describes, in general terms, the machine configurations, capacities, model differences, features, and available options.

Chapter 2 - PRODUCT SPECIFICATIONS: Presents the physical, electrical, and environmental specifications of the 4600 Tape Subsystem.

Chapter 3 - CONTROLS AND INDICATORS: Describes the functions of all tape subsystem switches and indicators.

Chapter 4 - CHANNEL INTERFACE: Briefly describes the modes of data transfer and provides detailed definitions of the channel interface status and sense bytes.

Chapter 5 - DIAGNOSTICS: Describes the on-board diagnostics utilized by the 4600 Tape Subsystem.

Chapter 6 - INSTALLATION PLANNING: Provides general guidelines for planning the installation of the 4600 Tape Subsystem.

Appendix A - GLOSSARY

RELATED STORAGE TECHNOLOGY CORPORATION PUBLICATIONS

4600 Tape Unit Maintenance Manual, PN 95570
4600 Tape Control Unit Maintenance Manual, PN 95571
4600 Tape Subsystem Installation Manual, PN 95572
4600 Tape Subsystem Illustrated Parts Catalog, PN 95573
4500/4600 Tape Subsystem Diagnostics Manual, PN 95574

(INTENTIONALLY LEFT BLANK)

TABLE OF CONTENTS

Paragraph	Title	Page
CHAPTER 1 PRODUCT DESCRIPTION		
1.1	Introduction	1-1
1.2	General Description	1-1
1.2.1	Subsystem Description	1-4
1.2.2	Tape Control Unit Description	1-4
1.2.3	Tape Unit Description	1-5
1.3	Standard Features	1-7
1.4	Selective Features	1-8
1.5	Optional Features	1-8
CHAPTER 2 PRODUCT SPECIFICATIONS		
2.1	Introduction	2-1
2.2	Physical Dimensions	2-1
2.3	Electrical Characteristics	2-3
2.3.1	Primary Power	2-3
2.3.2	Power Consumption	2-3
2.3.3	Power Distribution And Control	2-4
2.3.4	Regulatory Agencies	2-5
2.4	Environmental Requirements	2-5
2.4.1	Temperature (Ambient Room Air)	2-5
2.4.2	Relative Humidity	2-5
2.4.3	Altitude	2-6
2.5	Heat Dissipation	2-6
CHAPTER 3 CONTROLS AND INDICATORS		
3.1	Introduction	3-1
3.2	Operator Control Panel	3-1
3.2.1	LOAD/REWIND Switch	3-1
3.2.2	START Switch	3-1
3.2.3	REWIND/UNLOAD Switch	3-3
3.2.4	RESET Switch	3-3
3.2.5	OFFLINE REQUEST Switch	3-3
3.2.6	WINDOW Switch	3-3
3.2.7	SELECT Indicator (Amber)	3-4
3.2.8	READY Indicator (Green)	3-4
3.2.9	WRITE DISABLED Indicator (Red)	3-4
3.2.10	TAPE INDICATE Indicator (Amber)	3-4
3.2.11	MACHINE CHECK Indicator (Red)	3-4
3.2.12	OFFLINE Indicator (Red)	3-4

TABLE OF CONTENTS CONT

Paragraph	Title	Page
3.3	Enable/Disable Panel	3-5
3.4	FE Panel	3-7
3.4.1	POWER ON Switch	3-7
3.4.2	MACH (Machine) RESET Switch	3-7
3.4.3	Initial Program Load (IPL) Switch	3-7
3.4.4	INLINE REQUEST Switch	3-7
3.4.5	OFFLINE Indicator	3-9
3.4.6	HEARTBEAT Indicator	3-9
3.4.7	IDLE LOOP Indicator	3-9
3.4.8	UNIT CHECK Indicator	3-9
3.4.9	REMOTE MAINT Indicator	3-9
3.4.10	Program Number Display	3-10
3.4.11	Data/Status Display	3-10
3.4.12	Prompt Card Kit	3-10
3.4.13	Data Entry Keypad	3-10
3.4.14	Execute Keys	3-10
3.4.15	Maintenance Port	3-11
3.5	Tape Unit Maintenance Panel	3-11

CHAPTER 4 CHANNEL INTERFACE

4.1	Introduction	4-1
4.2	Modes Of Data Transfer	4-1
4.3	Status Information	4-2
4.3.1	Status Modifier (Bit 1)	4-3
4.3.2	Control Unit End (Bit 2)	4-3
4.3.3	Busy (bit 3)	4-3
4.3.4	Channel End (Bit 4)	4-4
4.3.5	Device End (Bit 5)	4-4
4.3.6	Unit Check (Bit 6)	4-5
4.3.7	Unit Exception (Bit 7)	4-6
4.4	Sense Bytes	4-6
4.4.1	Sense Byte 0	4-8
4.4.2	Sense Byte 1	4-9
4.4.3	Sense Byte 2	4-10
4.4.4	Sense Byte 3	4-11
4.4.5	Sense Byte 4	4-12
4.4.6	Sense Byte 5	4-12
4.4.7	Sense Byte 6	4-13
4.4.8	Sense Byte 7	4-14
4.4.9	Sense Byte 8	4-14
4.4.10	Sense Byte 9	4-14
4.4.11	Sense Byte 10	4-15
4.4.12	Sense Byte 11	4-15

TABLE OF CONTENTS CONT

Paragraph	Title	Page
4.4.13	Sense Byte 12	4-16
4.4.14	Sense Byte 13	4-16
4.4.15	Sense Byte 14	4-17
4.4.16	Sense Byte 15	4-17
4.4.17	Sense Byte 16	4-17
4.4.18	Sense Byte 17	4-17
4.4.19	Sense Byte 18	4-17
4.4.20	Sense Byte 19	4-17
4.4.21	Sense Byte 20	4-18
4.4.22	Sense Byte 21	4-18
4.4.23	Sense Byte 22	4-18
4.4.24	Sense Byte 23	4-18

CHAPTER 5 DIAGNOSTICS

5.1	Introduction	5-1
5.2	Wake-Up Diagnostics	5-1
5.3	Functional/Reliability Tests	5-2
5.4	Detached Diagnostics	5-2
5.5	Error Log	5-2

CHAPTER 6 INSTALLATION PLANNING

6.1	Introduction	6-1
6.2	Subsystem Layout	6-1
6.3	Subsystem Floorspace	6-1
6.4	Cabling	6-3
6.4.1	A-Unit Power Cable	6-3
6.4.2	Emergency Power Off (EPO) Cable	6-4
6.4.3	Channel Bus and Tag Cables	6-4
6.4.4	Communicator Cables	6-4
6.4.5	TCU-TU Interface Cables	6-4
6.4.6	A-Unit Power Distribution Extension Cable	6-4

APPENDIX A GLOSSARY

INDEX

(INTENTIONALLY LEFT BLANK)

LIST OF ILLUSTRATIONS

Figure	Title	Page
1-1	4600 Tape Subsystem	1-2
1-2	4600 Tape Subsystem A- and B-Units	1-3
1-3	System Block Diagram	1-6
1-4	2x16 Configuration	1-9
2-1	Tape Subsystem Dimensions	2-2
3-1	Operator Control Panel	3-2
3-2	Enable/Disable Panel	3-6
3-3	FE Panel	3-8
3-4	Tape Unit Maintenance Panel	3-12
6-1	Floorspace Requirements	6-2

(INTENTIONALLY LEFT BLANK)

LIST OF TABLES

Table	Title	Page
1-1	Performance Specifications	1-5
2-1	Summary of Dimensions and Weights	2-1
2-2	Power Consumption	2-4
2-3	Temperature (Ambient Room Air)	2-6
2-4	Relative Humidity	2-6
2-5	Heat Dissipation	2-8
4-1	Channel Interface Lines	4-2
4-2	4600 Sense Bytes	4-7
6-1	External Subsystem Cable Types	6-3
6-2	Channel Cable Length Restrictions	6-5

(INTENTIONALLY LEFT BLANK)

CHAPTER 1

PRODUCT DESCRIPTION

1.1 INTRODUCTION

The 4600 Tape Subsystem is a nine-track tape transport and control unit designed to be attached to the IBM (or compatible) 370/135, 138, 145, 148, 155, 158, 3000 or 4000 systems.

One 4600 Tape Control Unit and two 4600 Tape Units are shown in Figure 1-1.

1.2 GENERAL DESCRIPTION

The 4600 Tape Subsystem is packaged in two types of tape units (Figure 1-2): The A-unit contains a Tape Control Unit (TCU), a tape unit (TU), and a maintenance facility; the B-unit contains a tape unit only. The minimum tape subsystem is one A-unit (1x1). From one to seven additional TUs (B-units) are attached to the A-unit TCU for a 1x8 maximum configuration. The Communicator option permits the addition of a second TCU with its TUs for a 2x16 maximum configuration.

A principal innovation of the 4600 Tape Subsystem is the extensive application of microprocessor technology used for control functions previously requiring many logic circuits. The use of microprocessors makes possible an extremely compact subsystem with unique operational advantages. Foremost among these advantages is the ability to attach TUs of different characteristics (tape velocity and data format) to a single TCU.

Microprocessors in the TCU provide more complete and accurate TU control without the necessity of being devoted to the particular TU which is operating. Another important feature of the 4600 Tape Subsystem is its extensive diagnostic capability. Through the subsystem diagnostics, the field engineer can test the condition of the tape subsystem, online (inline diagnostics) or offline.

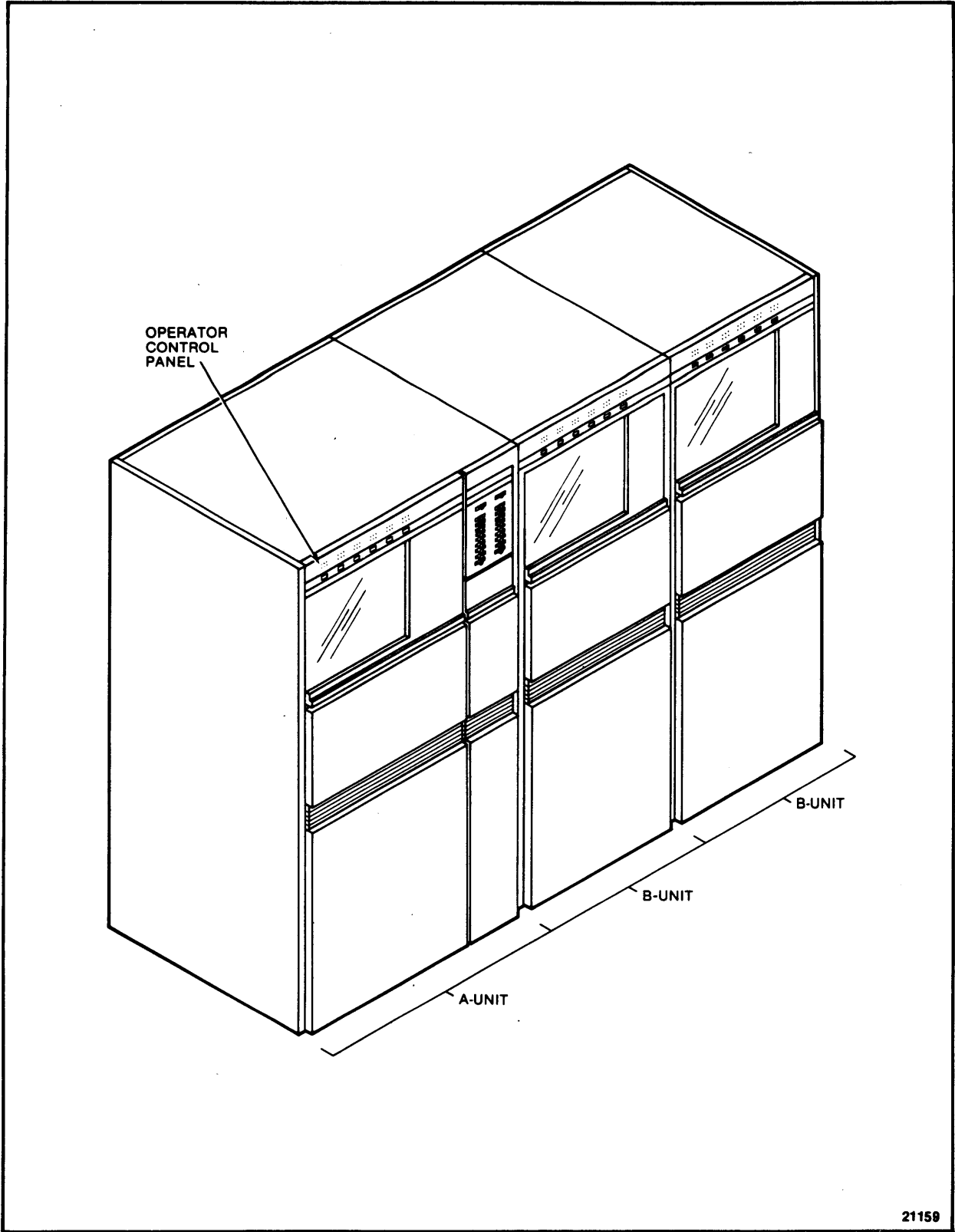

Figure 1-1. 4600 Tape Subsystem

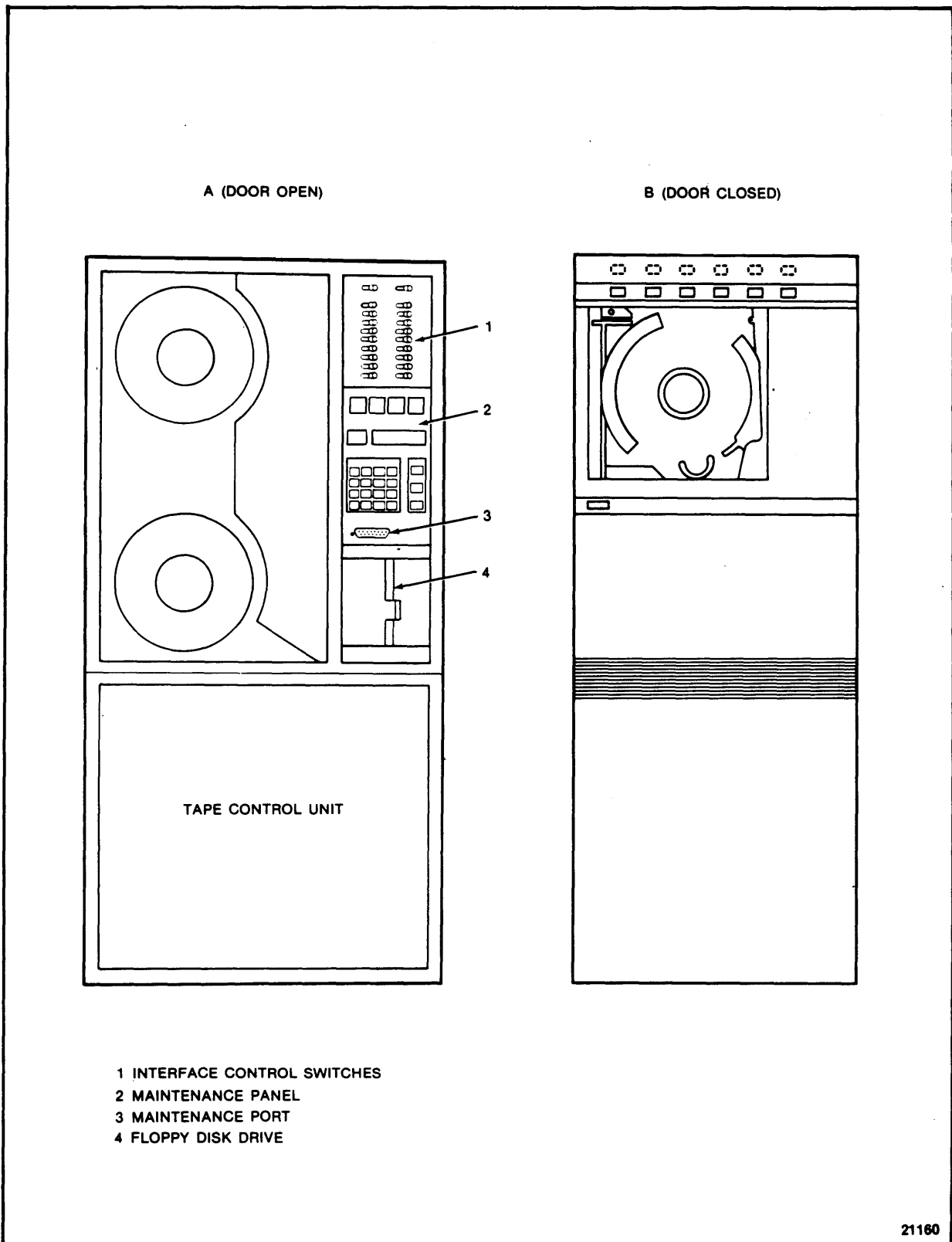

Figure 1-2. 4600 Tape Subsystem A- and B-Units

The 4600 Tape Subsystem writes and reads magnetic tapes as specified by ANSI X3.54-1976 (GCR) and ANSI X3.39-1973 (PE). The tapes are bilaterally interchangeable to other tape subsystems, including IBM subsystems, if those subsystems are compatible to the ANSI standards.

The 4600 Tape Subsystem is available in two basic models; 4670/74 and 4650/54. The 4670 is comprised of a 200 ips tape drive and an integrated control unit. The 4674 is a 200 ips tape drive only. The 4650 is comprised of a 125 ips tape drive and an integrated control unit. The 4654 is a 125 ips tape drive only.

The 4600 offers configuration flexibility as the 4674 and 4654 can be intermixed within a string, allowing for attachment to a 4670 or 4650 control unit.

Performance specifications for the subsystem are listed in Table 1-1.

1.2.1 Subsystem Description

Figure 1-3 shows the relationship of the channel, TCU, and TUs. The TCU connects to the channel through two cables: Bus and Tag. The Bus lines inbound to the TCU carry device addresses, data to be recorded, and commands to the TCU; the Bus lines outbound from the TCU carry device identification, data retrieved from tape, and status information to the channel. The Tag lines indicate the type of information on the Bus lines.

Write data lines, read data lines, control lines, and status lines connect the TCU to the TUs. Write data lines carry the data to be recorded on tape; read data lines carry data retrieved from tape to the TCU. Control lines carry operational and performance information to the TCU.

1.2.2 Tape Control Unit Description

The TCU provides the interface to the channel, controls the operation of the TU, and formats or deformats the data to be recorded on or retrieved from tape. The TCU is divided into five major functional areas: interface channel adapter (ICA), formatter, write sequencer, read sequencer, and tape unit adapter (TUA). The TCU interface channel adapter is designed to interface with an IBM 360/370 selector or block multiplexer channel, making the channel type invisible to the formatter and the TUA.

1.2.3 Tape Unit Description

The TU is designed to read and write ANSI-compatible, half-inch, nine-track magnetic tape at 200 or 125 ips.

Table 1-1. Performance Specifications

Models	A-Unit B-Unit	4670 4674	4650 4654
Tape Velocity		200 ips	125 ips
Recording Formats		GCR PE	GCR PE NRZI
Data Rates			
GCR (6250 bpi)		1250 kb/s	781 kb/s
PE (1600 bpi)		320 kb/s	200 kb/s
NRZI (800 bpi)		N/A	100 kb/s
Write Access Time (nominal)			
GCR		1.48 ms	1.6 ms
PE		1.48 ms	1.6 ms
NRZI		N/A	2.4 ms
Interblock Gap			
GCR		0.30 in 0.76 cm	0.30 in 0.76 cm
PE		0.60 in 1.52 cm	0.60 in 1.52 cm
NRZI		0.60 in 1.52 cm	0.60 in 1.52 cm
Rewind Time (2400-foot reels)		50 sec (nominal)	60 sec (nominal)
Load/Unload Time (10.5 ft leader)		10 sec	10 sec

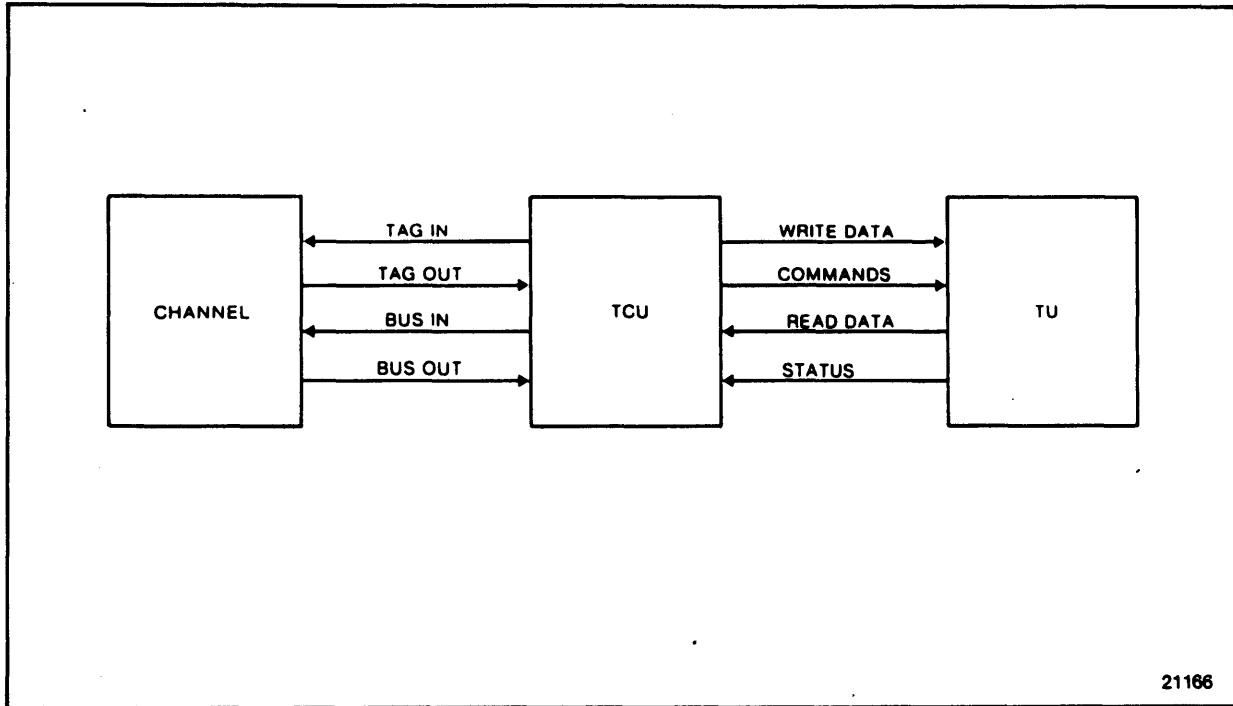

Figure 1-3. System Block Diagram

All TU configurations have the capability to write and read group-coded recording (GCR) format data at 6250 bpi and phase encoded (PE) format data at 1600 bpi. The TU is conditioned for the data to be recorded or read by the program from the tape control unit (TCU) when the tape is positioned at the beginning of tape (BOT) marker.

The TU reads when tape is moving either forward or backward but data recording is performed only during forward tape motion. Separate write and read data paths permit read during write to provide immediate verification of recorded data.

The tape transport mechanism is mounted on an aluminum deck casting which is mounted on hinges to provide access for maintenance to all elements of the TU behind the casting and inside the electronics frame.

1.3 STANDARD FEATURES

For optimal performance and reliability, the 4600 Tape Subsystem is equipped with an extensive set of standard features.

- Single Vacuum-Assisted Capstan: Ensures positive tape-to-capstan contact.
- Dual Vacuum Columns: Provides sufficient tape slack for maximum tape control within a compact space.
- Power Window (Plexiglass): Automatically lowers into the open position following the completion of a tape unload operation and automatically raises prior to a tape threading operation.
- Automatic File Reel Hub: A quick-release high-torque hub, pneumatically operated to ensure fast, positive attachment of file reels.
- Automatic Tape Thread and Load: Automatically feeds the tape leader (including the leader from open reels) through the threading channel and loads the tape into the columns.
- Dual-Gap Read/Write Head with Full-Width Erase Head: Provides improved data transfer between head and tape and permits a read-after-write operation for data transfer accuracy verification.
- Head Azimuth Adjustment: Facilitates precise parallel alignment of the read/write and the tape.
- Vacuum-Assisted Tape Cleaner: Reduces particulate contamination of the tape for enhanced data read/write accuracy.
- Beginning of Tape and End of Tape Sensing: Ensures accurate tape handling control by electronically sensing the beginning of tape (BOT) and end of tape (EOT) markers.
- File Protect: Protects against accidental erasure of data files.
- Microprogram Control: Provides greater system adaptability, improved tape unit control, and extensive subsystem diagnostics.
- Resident Maintenance Controls: Allows the operator or field engineer to initialize the subsystem, perform maintenance functions and diagnostic tests, and force certain TCU operations; status information is provided by indicators on the control panel.

1.4 SELECTIVE FEATURES

The specifications of the following features are chosen by the customer prior to shipment of the subsystem. Conversions can be performed in the field, if necessary.

- Nominal Input Power: 200, 208, or 240 Vac at 60 Hz; 380 or 408 Vac at 50 Hz.
- Altitude Range: The pneumatics system is adaptable to three altitude ranges: 0 to 1100 ft (0 to 330 m) or 1100 to 6000 ft (330 to 1800 m); for high altitudes, a pulley option provides a range of 6000 to 8500 ft (1800 to 2550 meters).

1.5 OPTIONAL FEATURES

There are several options available for the 4600 Tape Subsystem. Each option is installed in the field or at the time of manufacture. Following is a list of the available options:

- Two or Four-Channel Switch: Permits a second, third or fourth channel (from the same or separate processors) to access the TCU. The additional channels can be IBM 360/370 selector or 4300/3000 series block multiplexer. The switch can be under manual or program control.
- Communicator: Permits the addition of a second TCU for a maximum subsystem configuration of two A-units and fourteen B-units (2x16) as shown in Figure 1-4. Either TCU can address any tape unit within the subsystem. Any or all TUs can be rendered inaccessible to either or both TCUs by switches on the enable/disable panel.
- Tri-density: The Tri-density feature is available on the 4650/54 for 800 bpi for the 125 ips units only.
- Tape Accelerator: A high-speed, 32 kilobyte (Kb) buffer that accelerates the throughput capacity of the subsystem by allowing data transfers to occur at maximum channel rate. The TCU equipped with the buffer option accepts read/write commands from the processor in the normal manner, then disconnects from the channel, leaving the channel free for other operations while the buffer manages data transfer to or from the TU. With this option, a single record can be transferred at a rate of up to 3 megabytes per second (Mb/s) on a data streaming channel.

Please note the following restriction for the StorageTek Tape Accelerator feature: The I/O operations that perform write data chaining are not supported.

There are additional operating system and application program restrictions that must be observed when using the Tape Accelerator feature. Refer to the StorageTek Buffered Tape Guide (DOC. NO. ET 0540) for a complete description of these restrictions.

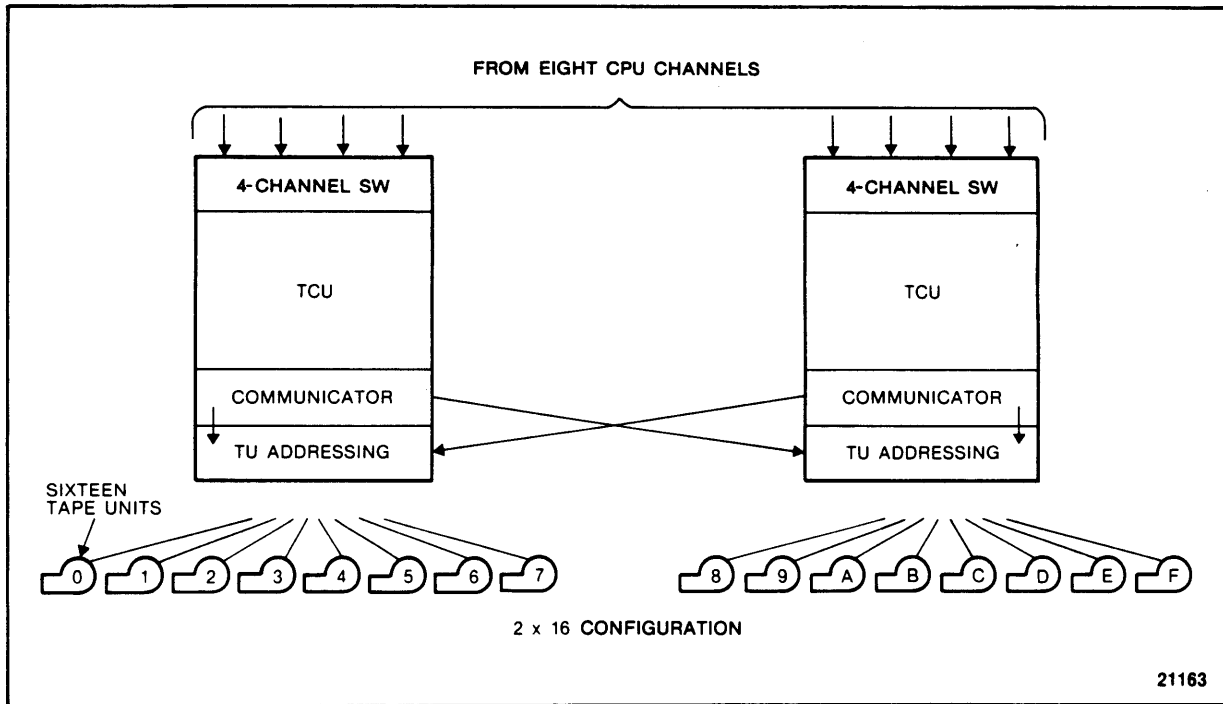

Figure 1-4. 2x16 Configuration

(INTENTIONALLY LEFT BLANK)

CHAPTER 2

PRODUCT SPECIFICATIONS

2.1 INTRODUCTION

The specifications of the tape unit (TU) include physical dimensions, electrical characteristics, environmental requirements, and heat dissipation. This information is invaluable when planning the installation of the 4600 Tape Subsystem.

2.2 PHYSICAL DIMENSIONS

Table 2-1 contains the dimension and weight description of the 4600 Tape Control Unit (A-Unit) and the Tape Unit (B-Unit) in metrics and U.S. standards.

Table 2-1. Summary of Dimensions and Weights

Dimension/Weight	A-Unit	B-Unit
Height	62.0 in 1574.8 mm	62.0 in 1574.8 mm
Width	32.4 in 823.0 mm	24.0 in 609.6 mm
Depth	29.75 in 755.65 mm	29.75 in 755.65 mm
Weight Uncrated	768 lb 345.6 kg	488 lb 219.6 kg
Weight Crated	861 lb 387.5 kg	588 lb 251.1 kg

Dimensions are given for the width of the A and B-units without side covers (See Figure 2-1). Two side covers are shipped with the A-unit but are removed during subsystem installation to be attached to the exposed ends of the subsystem. Each side cover is 0.75 in (19 mm) thick, for an addition of 1.5 in (38.1 mm) to the overall width of the subsystem assembly.

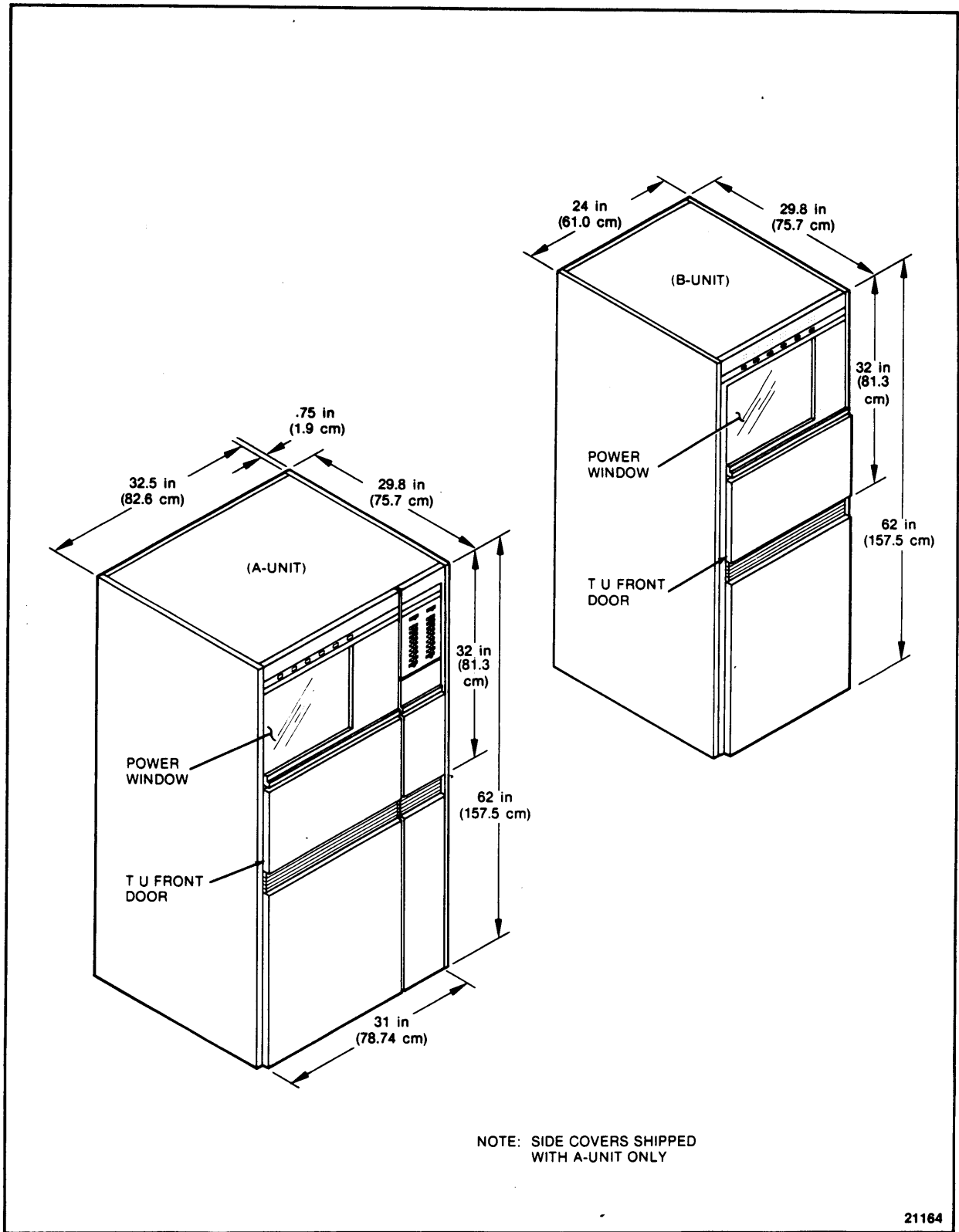

Figure 2-1. Tape Subsystem Dimensions

2.3 ELECTRICAL CHARACTERISTICS

The following paragraphs describe the 4600 Tape Subsystem's electrical characteristics.

2.3.1 Primary Power

The tape subsystem receives its primary power through a three-phase power distribution system. Internal cables connect from one unit to the next in the string, rotating the phases in each unit. No phase rotational sequence need be observed on the input cable to the system.

The subsystem is conditioned for the input power by jumpers on the primary side of the input power transformers. These jumpers are installed at the factory and may be changed at the customer site if necessary. The tape subsystem is operated from any one of the following ac power sources:

- 60 Hz (± 0.5 Hz) primary power;
 - 200 Vac (+6% -10%), phase-to-phase
 - 208 Vac (+6% -10%), phase-to-phase
 - 240 Vac (+6% -10%), phase-to-phase

- 50 Hz (± 0.5 Hz) primary power;
 - 380 Vac (+6% -10%), phase-to-phase
(operated phase-to-neutral to provide 220 Vac to each unit)
 - 408 Vac (+6% -10%), phase-to-phase
(operated phase-to-neutral to provide 235 Vac to each unit)

2.3.2 Power Consumption

For 60 Hz voltages (V), the service requirement is 60 amps/phase; for 50 Hz voltages, the service requirement is 40 amps/phase. Refer to Table 2-2 for the power consumption of the 4600 model types.

Table 2-2. Power Consumption

Power Data	4670	4674	4650	4654
KVA				
Operating, 50Hz/60Hz	2.4/2.1	1.7/1.5	2.2/1.9	1.5/1.3
Ready, 50Hz/60Hz	1.9/1.8	1.3/1.2	1.8/1.7	1.2/1.1

2.3.3 Power Distribution And Control

The power distribution system is comprised of the main power distribution assembly (PDA) in the A-unit and subsidiary PDAs in the B-units. The power distribution system provides three-phase ac power for distribution to the A-units and the B-units in a manner which balances the phases in a subsystem of any size. Power is supplied phase-to-phase in 60 Hz subsystems and phase-to-neutral in 50 Hz subsystems. (No phase sequence need be observed as no equipment is operated three-phase.)

The A-unit PDA provides ac power to the B-units as well as to the A-unit and also sequences power on and emergency powers off (EPO) within the tape subsystem. The power on sequence is: A-unit TCU, A-unit TU, right side B-units, left side B-units. There is a delay of 25 milliseconds (ms) between the power up of each unit.

Power is controlled by a circuit breaker on the A-unit PDA, circuit breakers on each A-unit power supply and the TCU power supply, REMOTE/LOCAL switches on each A-unit and B-unit PDA, and the POWER ON switch on the FE panel. Power is either remotely or locally controlled.

Remote Power Control: With all circuit breakers in the ON position, all REMOTE/LOCAL switches in the REMOTE position, and the FE panel POWER ON switch in the unlatched position, subsystem power is remotely controlled by the processor through the EPO cable. The subsystem returns a signal through the EPO cable to the processor to indicate the successful completion of the power on sequence.

Local Power Control: With all circuit breakers in the ON position, the A-unit PDA REMOTE/LOCAL switch in the LOCAL position, and all B-unit PDA REMOTE/LOCAL switches in the REMOTE position, subsystem power is locally controlled by the FE panel POWER ON switch.

2.3.4 Regulatory Agencies

- Underwriters Laboratories (UL): The 4600 Tape Subsystem has UL478 listing (208 Vac, 60 Hz operation only).
- Canadian Standards Association (CSA): The 4600 Tape Subsystem has CSA Standard C22.2 No. 154-1975 certification (208 Vac, 60 Hz operation only).
- Verband Deutscher Elektrotechniker (VDE): The 4600 Tape Subsystem is designed with respect to VDE requirements, and has been tested for certain Electromagnetic Charge (EMC) and Electromagnetic interference (EMI) characteristics.
- Federal Communications Commission (FCC): The 4600 Tape Subsystem complies with the FCC Part 15 for both conducted and radiated emissions.

2.4 ENVIRONMENTAL REQUIREMENTS

The following are the environmental conditions in which the tape subsystem data integrity is guaranteed. However, these requirements are for only the tape subsystem and not for the magnetic media or any auxiliary equipment.

2.4.1 Temperature (Ambient Room Air)

The storage environment must not be outside the limits of the operating environment longer than six months. The shipping environment must not be outside the limits of the storage environment for a period longer than 72 hours. Temperature requirements for operating, storage and shipping are given in Table 2-3.

2.4.2 Relative Humidity

The storage environment must not be outside the limits of the operating environment longer than six months. The shipping environment must not be outside the limits of the storage environment longer than 72 hours. Relative humidity requirements for operating, storage and shipping are given in Table 2-4.

Table 2-3. Temperature (Ambient Room Air)

Condition	°Centigrade	°Fahrenheit
Optimum	+16°C to +22°C	+60°F to +72°F
Operating	+16°C to +32°C	+60°F to +90°F
Storage	+10°C to +43°C	+50°F to +110°F
Shipping	-40°C to +60°C	-40°F to +140°F

Table 2-4. Relative Humidity

Condition	Allowable Relative Humidity
Optimum	37% to 42%, non-condensing
Operating	20% to 80%, non-condensing
Storage	10% to 90%, non-condensing
Shipping	Any, non-condensing

2.4.3 Altitude

Altitude requirements for operating and non-operating conditions follow:

Operating: 0 to 6000 ft (0 to 1800 m)
 6000 to 85000 ft (1800 to 2550 m)
 with high altitude option

Non-Operating: 0 to 50,000 ft (0 to 15 240 m)

2.5 HEAT DISSIPATION

Table 2-5 provides the heat dissipation rates of the 4600 Tape Subsystem model types.

Table 2-5. Heat Dissipation

MODEL	OPERATING 50/60 HZ.	READY 50/60 HZ.
4670 TCU/TU	7200/6800 ¹ 1800/1700 ²	6100/5700 ¹ 1500/1400 ²
4674 TU	5200/4800 ¹ 1300/1200 ²	4200/4000 ¹ 1100/1000 ²
4650 TCU/TU	6300/5900 ¹ 1600/1500 ²	5800/5400 ¹ 1500/1400 ²
4654 TU	4500/4200 ¹ 1100/1000 ²	3900/3700 ¹ 1000/900 ²
¹ Values given in BTU/HR ² Values given in KCAL/HR		

(INTENTIONALLY LEFT BLANK)

CHAPTER 3

CONTROLS AND INDICATORS

3.1 INTRODUCTION

This chapter describes the controls and indicators on the 4600 Tape Subsystem. The controls and indicators include those that are accessible to and used by the operator for normal operations and those that are available to trained and qualified personnel for maintenance and diagnostic functions.

3.2 OPERATOR CONTROL PANEL

The operator control panel contains switches to permit operation of the TU and indicators to provide TU status information. Touch sensitive membrane switches are used on the 4600 TCU and TU, making the operator control panel flush with the outside of the units. Figure 3-1 shows the operator control panel and, in the insert, its location on the TU.

3.2.1 LOAD/REWIND Switch

If the TU is not already loaded, pressing the LOAD/REWIND switch closes the window, latches the file hub, and initiates the automatic thread/load operation. If the TU is loaded, pressing the LOAD/REWIND switch initiates a rewind to BOT. The switch is operational only when the READY and MACHINE CHECK indicators are not illuminated.

3.2.2 START Switch

Pressing the START switch places the TU in Ready Status enabling the TU to accept commands from the TCU provided that the TU is loaded. If the TU is performing a thread/load operation when the START switch is pressed, the TU enters Ready Status when the tape reaches BOT.

Pressing the START switch when the TU is in a quiescent state enables the auto thread/load operation and places the TCU in Ready Status with a single switch press.

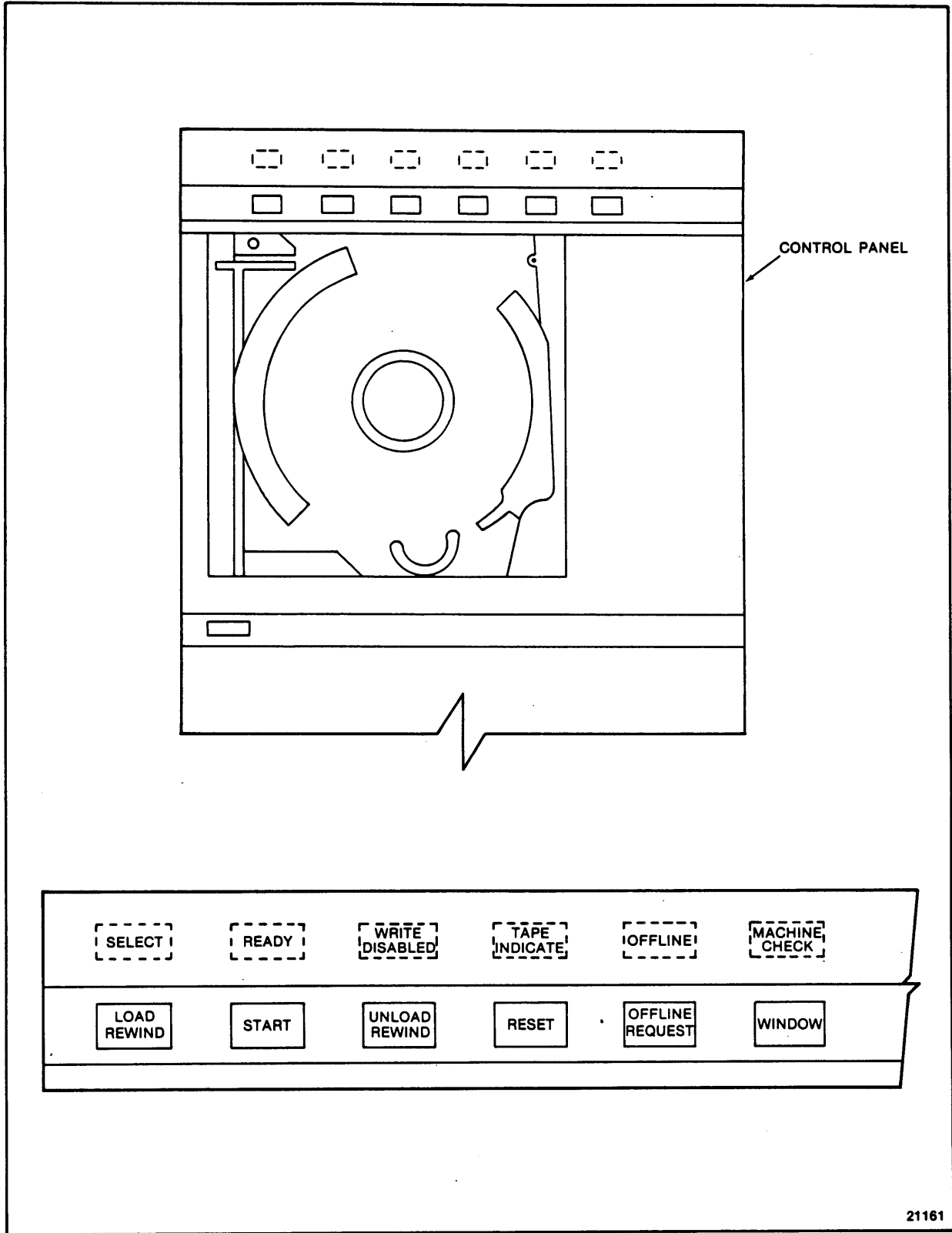

Figure 3-1. Operator Control Panel

3.2.3 REWIND/UNLOAD Switch

If a tape is present in the columns, pressing the REWIND/UNLOAD switch initiates a high speed rewind to BOT. When BOT is detected, the tape unloads onto the file reel (this conditions the power window, cartridge, and file hub to allow removal of the file reel). The switch is operational only when the READY and MACHINE CHECK indicators are not illuminated.

3.2.4 RESET Switch

Pressing the RESET switch ends the TU Ready Status, allowing the use of the other operator control panel switches.

Pressing the RESET switch also clears a machine check if the condition causing the check is no longer present.

Pressing the RESET switch once during a high-speed rewind operation slows the tape to normal tape speed. Pressing RESET a second time stops the tape completely. Pressing RESET during a rewind/unload operation affects rewind as described and unload is either prevented or is halted if already in progress by the disabling of both the pneumatics and reels systems.

Pressing the RESET switch during a load operation terminates the operation, leaving the TU in one of two possible states: If a tape is loaded into the columns, RESET halts the search for BOT but keeps the pneumatics and reels systems enabled (pressing the REWIND switch resumes the search for BOT). If a tape is not loaded into the columns, pressing RESET disables both pneumatics and reels systems.

3.2.5 OFFLINE REQUEST Switch

The OFFLINE REQUEST switch determines TU availability to the channel. If the TU is in Offline Status, pressing OFFLINE REQUEST changes the TU to Online Status. If the TU is in Online Status, pressing OFFLINE REQUEST changes the TU to Offline Status following the completion of the current command.

3.2.6 WINDOW Switch

If the TU is unloaded and the window is in the down position, pressing the WINDOW switch causes the window to move to the up position provided there are no obstructions.

If the TU is unloaded and the window is in the up position, pressing the window switch causes the window to move to the down position provided there are no obstructions.

3.2.7 SELECT Indicator (Amber)

Illumination of SELECT indicates that the TU is selected for use by the TCU.

3.2.8 READY Indicator (Green)

Illumination of READY indicates that the TU is loaded with tape and is in Ready Status.

3.2.9 WRITE DISABLED Indicator (Red)

The WRITE DISABLED indicator illuminates when the TU is not in Ready Status or when a write enable ring is not in place on the file reel. Write operations are prohibited when the write enable ring is absent.

3.2.10 TAPE INDICATE Indicator (Amber)

The TAPE INDICATE indicator illuminates when the end-of-tape (EOT) marker is at or past the EOT sensor. The indicator remains lit until a backward read or rewind operation moves the EOT marker back past the EOT sensor. EOT Status is automatically reset when a rewind operation is initiated.

3.2.11 MACHINE CHECK Indicator (Red)

Flashing of the MACHINE CHECK indicator indicates a load check which is operator-correctable; continuous illumination indicates a malfunction requiring service by a field engineer (FE).

3.2.12 OFFLINE Indicator (Red)

Illumination of the OFFLINE indicator indicates that the TU is in Offline Status.

3.3 ENABLE/DISABLE PANEL

The enable/disable panel is located on the A-unit and contains a vertical bank of switches that control channel access to the individual TUs. Figure 3-2 shows the enable/disable panel for a 2x16 configuration. The switch must be in the Enable position to allow channel access to the associated TU. If the switch for a TU is transferred from the Enable to the Disable position while that TU is selected by the channel, it will have no immediate effect: the TU remains active until the I/O operation in progress is completed and Select is reset.

On tape subsystems with the communicator feature installed, the panel contains two vertical banks of switches to permit manual partitioning of the 2x16 tape subsystem. These switches control access to the TUs from either TCU of a 2x16 tape subsystem. The left bank controls access from the host TCU to its directly connected TUs. The right bank controls access from the non-host or communicated TCU to the host TCUs directly connected TUs. In addition, the panel also contains switches to enable/disable the access of up to four channels to the tape subsystem.

If the optional tape accelerator feature is installed, the enable/disable panel contains up to four accelerate/normal switches per channel. In the accelerate position the switch enables the TCU's disconnect request (buffered tape I/O) to the attached channel. In the normal position, the switch disables the TCU's disconnect request (non-buffered or selector mode tape I/O) to the attached channel.

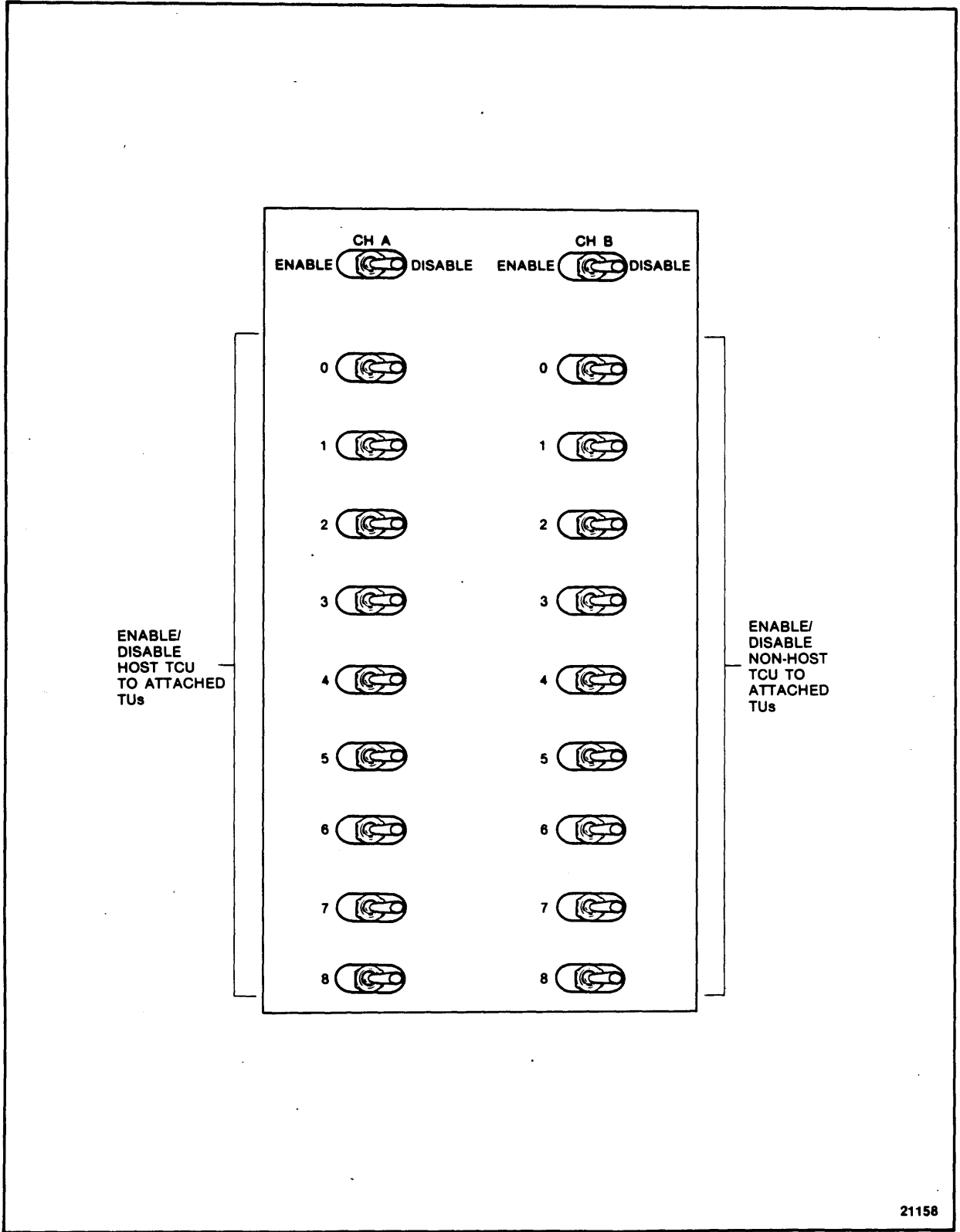

21158

Figure 3-2. Enable/Disable Panel

3.4 FE PANEL

The FE panel (Figure 3-3) is located at the A-unit maintenance facility. It permits local power control and initialization of the tape subsystem, performance of maintenance functions, performance of diagnostic routines and the forcing of certain TCU operations. Indicators on the panel provide status information.

3.4.1 POWER ON Switch

POWER ON switch is a combined alternate action switch and indicator. Depressing the POWER ON switch powers and initializes the tape subsystem. The POWER ON switch must be in the unlatched (out) position to permit remote power on. The POWER ON indicator is illuminated when power is on.

3.4.2 MACH (Machine) RESET Switch

MACH RESET switch is a combined momentary switch and indicator. When the MACH RESET switch is pressed, the microprocessor terminates the execution of the current program and re-initializes the TCU. The MACH RESET indicator illuminates when a parity error is detected in the formatter microprocessor memory.

3.4.3 Initial Program Load (IPL) Switch

Initial Program Load (IPL) switch is a combined momentary switch and indicator. Pressing the IPL switch initializes the TCU, accessing an IPL which contains wake-up tests and a diskette loader program to load the first track into memory. The IPL indicator is illuminated throughout the IPL process.

3.4.4 INLINE REQUEST Switch

INLINE REQUEST switch is a combined alternate action switch and indicator which generates an inline request to the TCU. Pressing the INLINE REQUEST switch while the TCU is operating enables input from the FE panel or 3920 or 3925 Detached Diagnostic Device (DDD), stores any current error log information and prevents any further error logging until the INLINE REQUEST switch is released.

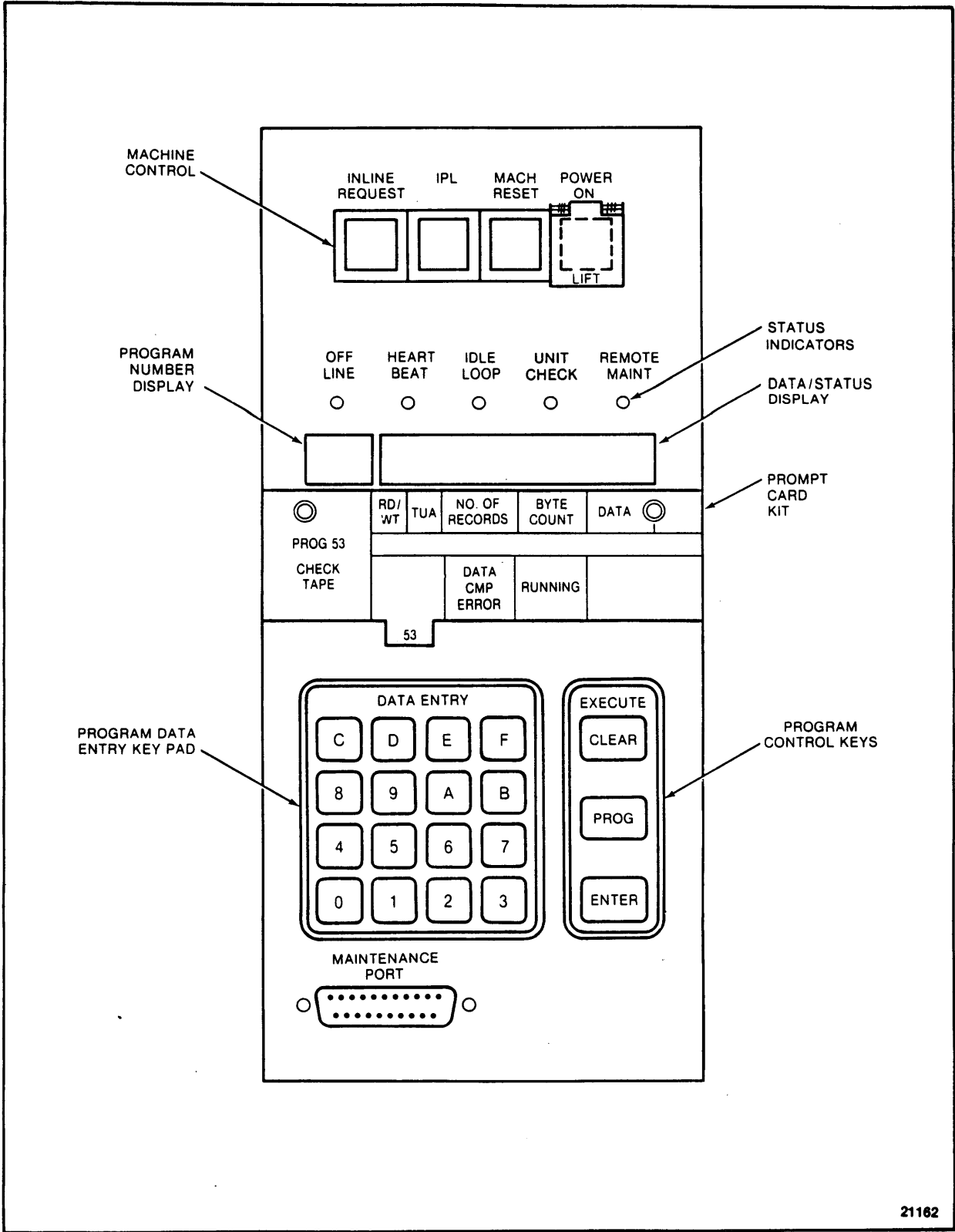

Figure 3-3. FE Panel

At IPL, the status of Inline Request determines whether the TCU is brought online. If the Inline Request is on, the TCU is not brought online and the Offline indicator is illuminated. If Inline Request is off, the TCU is brought online.

The INLINE REQUEST indicator illuminates when the INLINE REQUEST switch is depressed.

3.4.5 OFFLINE Indicator

The OFFLINE indicator illuminates when the TCU is offline to the channel.

3.4.6 HEARTBEAT Indicator

The HEARTBEAT indicator is illuminated when the TCU is operating. The HEARTBEAT indicator is controlled by a subroutine of the operating system microcode. If the subroutine is not accessed within a given time limit, a delay times out, the indicator is extinguished, and an alarm is sounded. Pressing the IPL switch starts the program and illuminates the HEARTBEAT indicator.

3.4.7 IDLE LOOP Indicator

The IDLE LOOP indicator illuminates when the subsystem operating program is in its idle loop, that is, awaiting an instruction from the ICA or maintenance facility. The IDLE LOOP indicator extinguishes during processing.

3.4.8 UNIT CHECK Indicator

The UNIT CHECK indicator illuminates when a Unit Check is detected. (The UNIT CHECK indicator does not illuminate during an IPL sequence failure.)

3.4.9 REMOTE MAINT Indicator

The REMOTE MAINT (maintenance) indicator illuminates when a 3920/25 DDD or acoustic coupler is connected and data is being transferred.

3.4.10 Program Number Display

The Program Number Display is a two-digit display that indicates the number of the current FE panel program being executed or it displays an IPL error code.

3.4.11 Data/Status Display

The Data/Status Display is an eight-character display which indicates variable program data and test status for FE panel programs. Field delimiters are displayed as periods; dashes are displayed in areas not being used.

3.4.12 Prompt Card Kit

The prompt card kit is a set of charts that identify the fields of the program number, the data/status displays and the program status LEDs. Each chart uniquely identifies a specific FE panel program. When a program is called, the upper half of the chart identifies the fields into which the program has divided the data/status display.

3.4.13 Data Entry Keypad

The Data Entry keypad is a hexadecimal keypad used to enter program numbers and program parameters. The Execute keys (CLEAR, PROG, and ENTER) to the right of the keypad are used to control data entered on the keypad.

3.4.14 Execute Keys

Pressing the ENTER key causes data entered at the keypad to be entered into a data register in the FE panel and initiates program execution. During execution of some FE panel programs, the ENTER key has special functions which are described in the 4600 Tape Subsystem Diagnostics Manual.

Pressing the CLEAR key before the Enter key clears the current keypad entry. The CLEAR key is also used for special functions defined in the 4600 Tape Subsystem Diagnostics Manual.

Pressing the PROG key cancels the current program and enables the keypad to input a new program number.

3.4.15 Maintenance Port

The maintenance port is an RS-232-C connector used to attach a 3920/25 DDD or an acoustic coupler to the TCU for additional diagnostic capacity. This port accesses only the diagnostic capacity. This port accesses only the diagnostic programs of the TU.

3.5 TAPE UNIT MAINTENANCE PANEL

A circuit card in the TU contains a tape unit maintenance panel (Figure 3-4). This panel provides a set of switches for invoking TU test procedures and an eight-bit display for monitoring TU performance and status. The tests are used for exercising TU components, for examining microprogram storage areas, and for exercising the TU.

The control switches are:

- Start/Reset: A bidirectional momentary toggle switch used for invoking a test and stepping through it; also used to exit a test by resetting the TU.
- Backward/Forward: a bidirectional momentary toggle switch used for selecting the direction of tape motion.
- Maintenance Control: An eight-bit position slide DIP switch used for selecting the test (three Program Select switches) and for setting test variables (such as write density).
- Variables Select: An eight-bit position slide DIP switch used for setting test variables such as write bit selection and shoeshine rate.
- IPL Request: A unidirectional momentary toggle switch used to initiate a TU IPL sequence.

Eight LED indicators display various maintenance test information. If a machine check is detected during normal tape operations, these indicators display a machine check code.

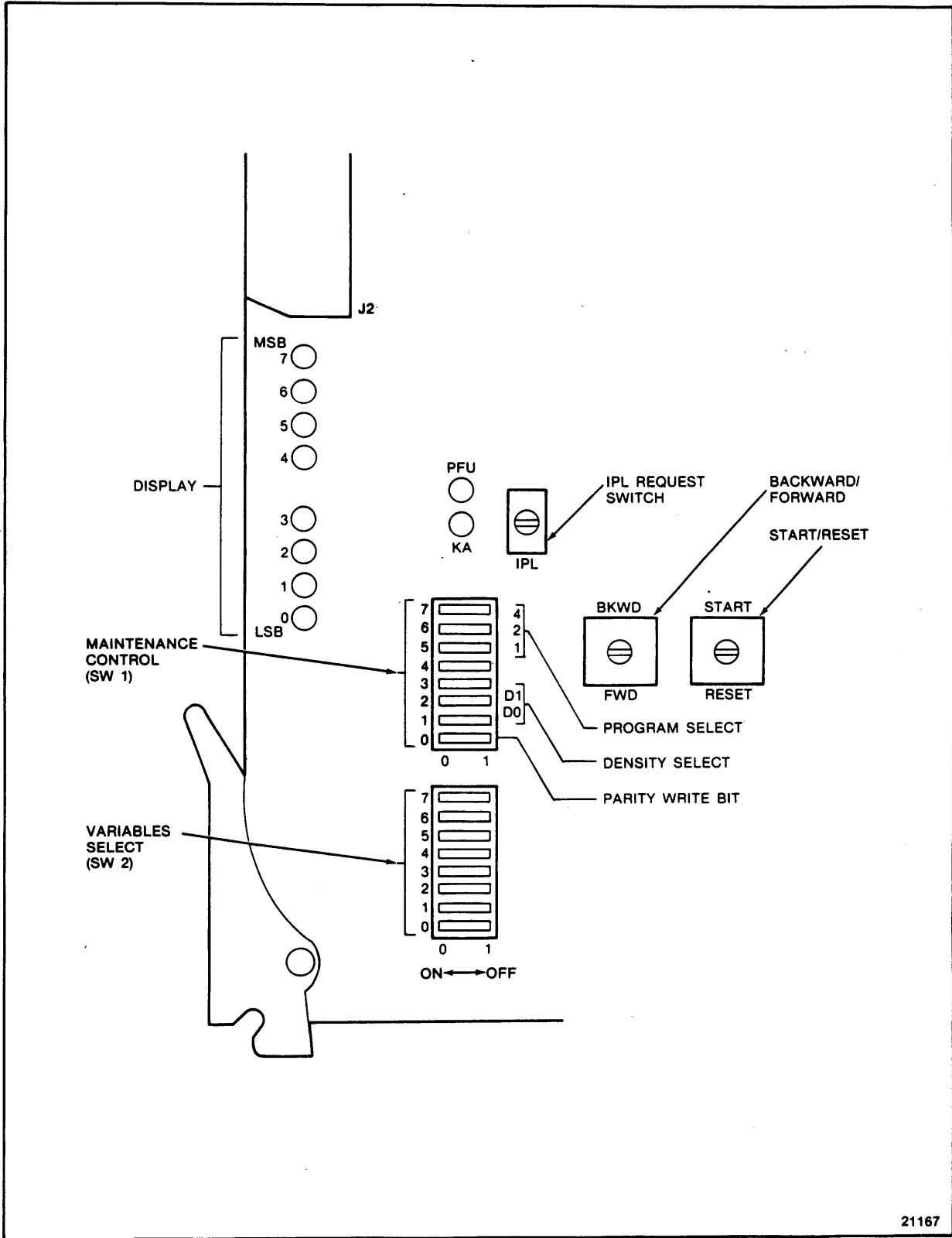

Figure 3-4. Tape Unit Maintenance Panel

CHAPTER 4

CHANNEL INTERFACE

4.1 INTRODUCTION

The channel interface is comprised of bus lines, tag lines, selection control lines, and a mark line, through which the 4600 Tape Control Unit (TCU) and channel exchange control and data signals (Table 4-1). The TCU decodes commands received from the channel, interprets the commands for the tape units (TUs), and provides the signal sequence for executing the operation.

4.2 MODES OF DATA TRANSFER

Selection of a TCU is controlled by a signal that permits each TCU to respond to channel signals sequentially. A TCU remains logically connected to the channel until information is exchanged or until the channel signals the TCU to disconnect.

There are four modes of data transfer that may be specified on an interface basis: DC Interlock, Offset Interlock, Service In Only, and Data Streaming at up to 3 megabytes per second (Mb/s):

- DC Interlock sequences remove dependence on circuit speed and make the interface applicable to a wide variety of circuits and data rates. DC Interlock transfers data using Service In-Service Out and Data In-Data Out tags in handshaking mode. The data rate established in DC Interlock is a function of cable length. All channels are capable of operating in DC Interlock mode.
- Offset Interlock mode permits the use of channel interface cables up to 350 ft (105 m) in length with no adverse effect on data transfer rate. Offset Interlock mode performs data transfer using Service In-Service Out and Data In-Data Out tags without handshaking. Offset Interlock mode operates on most block multiplexer channels.
- Service In Only mode uses only Service In-Service Out tags for handshaking. Service In Only mode operates on block multiplexer channels or selector channels.
- Data Streaming mode may be specified for up to 3 Mb/s data transfer rates and is applicable for read and write commands only; sense and control commands use DC Interlock.

When data streaming mode is specified in a standard 4600 TCU interface (without Tape Accelerator Feature #6551) data transfer occurs at device rate.

Table 4-1. Channel Interface Lines

LINE GROUP	LINE NAME	USE
Bus Out Lines	P,0-7	These lines are used to send information such as data, I/O device address, and commands from the channel to the TCU.
Bus In Lines	P,0-7	These lines are used to send information such as data, I/O identification, sense data, and status information from the TCU to the channel.
Tag Lines	Address Out Address In Command Out Status In Service Out Service In Data Out Data In Disconnect In	These lines are used for interlocking and controlling information on the buses and for any special sequences.
Selection Control Lines	Operational Out Operational In Hold Out Select Out Select In Suppress Out Request In	These lines are used for scanning or the selection of the attached I/O devices.
Mark Line	Mark 0 In	This line is used to request the command retry functions.

4.3 STATUS INFORMATION

The Status Byte is transmitted to the channel during the initial selection sequence, to present Channel End at the termination of data transfer, to present Device End or Control Unit End when the

TU or TCU become free, to present stacked status or to present externally-initiated status. Once the Status Byte has been accepted by the channel, it is reset and is not presented again. When Status In is up, the Status Byte appears on Bus In. The Status Byte indicates the current status of the TCU and the TU whose address appeared on Bus In with Address In during the polling or selection portion of the sequence.

When a TCU has the optional two-channel switch feature installed, the status resulting from channel-initiated operations are presented only to the channel that initiated the associated I/O operation.

4.3.1 Status Modifier (Bit 1)

Status modifier, when set with Busy (bit 3) set, indicates the TCU is busy rather than the TU. Status modifier is never presented alone.

4.3.2 Control Unit End (Bit 2)

The control unit end (CUE) bit indicates the following conditions:

- The TCU has previously responded to interrogation by a channel with a status byte containing the Busy and Status Modifier bits and is now available to communicate with the channel.
- The TCU detected a Unit Check or Unit Exception condition while it was busy, but after Channel End was accepted by the channel.

A pending CUE causes the TCU to appear unavailable for initiation of new operations. However, if CUE is being presented to one interface of a dual channel TCU, a short-busy sequence responds to an attempted selection by the other interface.

Control Unit End causes command chaining to be suppressed.

4.3.3 Busy (bit 3)

Busy indicates that a TCU or a TU cannot accept a command because it is executing a previously-initiated operation or that a status condition exists at initial selection. Busy status is presented only during an initial selection sequence and causes command chaining to be suppressed.

Busy As A Result Of Status: If the status condition that causes a busy indication is for the addressed TU, the Busy bit is set along with the existing status providing the command is other than Test I/O. If the status is not for the addressed TU, Status Modifier is set along with the Busy bit to indicate the TCU is busy.

Busy As A Result of Dual Channel Interface Operation: TCUs with the two-channel switch feature installed appear busy to one interface while they are attached or maintaining a contingent connection to the other interface. The status presented under such a situation is an Immediate Busy status.

TCUs with the two-channel switch feature also appear busy to one interface while a System Reset or Selective Reset is occurring on the other interface.

Busy As A Result of Inline Diagnostics: Execution of inline diagnostics causes a Short Busy response to an attempted selection by the channel interface.

4.3.4 Channel End (Bit 4)

Channel End indicates that the transfer of data or the control information portion of the I/O operation between the channel and the TCU is complete. Channel End is generated only once per I/O operation. Channel End is set when a Read, Read Backward, Write, or Sense command has been completed, or when a control command is accepted.

4.3.5 Device End (Bit 5)

Device End indicates the completion of an I/O operation at the TU. Each I/O operation causes only one Device End condition.

When command chaining is performed, the channel makes available to the program only the Device End for the last command in the chain. If the Device End is received without unusual conditions detected, the channel initiates the next command chain. If an unusual condition is detected, the command chain is terminated without presenting Device End.

If the two-channel switch option is installed and TUs are shared by the two channels, Device End is presented to both channels when a shared TU goes from the not-ready to the ready state.

Device End is set when any of the following conditions occur:

- A rewind/unload operation is completed at the TCU.

- When the tape reaches BOT during a rewind operation or EOT during a data security erase operation.
- A control command is completed at the TU.
- Other commands are completed, along with Channel End.
- On the first initial selection sequence after the TU becomes ready if the TCU is not armed.
- When a TU becomes not busy after selection was attempted while it was busy.
- If a selected TU drops Ready during an operation except upon acceptance of a Rewind, Rewind/Unload, or Data Security Erase (DSE) command.

4.3.6 Unit Check (Bit 6)

Unit Check indicates that the TU or TCU has detected an unusual condition. The conditions causing Unit Check are detailed by information available as sense data.

Unit Check may indicate a programming or equipment error, a not-ready state of a TU that has affected execution of a command, or an exceptional condition not included in the Unit Exception indication has occurred. An error condition sets Unit Check only during the execution of a command or when performing an activity associated with an I/O operation.

Unit Check is not set if the TCU can execute the command although the addressed TU has become not-ready as a result of the operation. Test I/O can clear the not-ready state of the TU without setting Unit Check. However, a subsequent Test I/O issued to the device causes a Unit Check indication. A Test I/O or No Operation command issued to a not-ready device with no interruption pending causes a Unit Check indication.

Unit Check is set when any of the following conditions occur:

- Any bit in sense byte 0 is set.
- A read backward, backspace block, or backspace file operation is initiated at or into BOT.
- A rewind/unload operation is completed at the TCU.
- Sense byte 1, bit 7 (Not Capable) is set.
- Sense byte 5, bit 3 (ID Burst Check) is set.

- Sense byte 1, bit 0 (Noise) is set.
- Mark 0 In and Status In rise indicating a command retry operation.
- Channel refuses command retry request by not indicating command chaining (buffered tape only).

4.3.7 Unit Exception (Bit 7)

Unit Exception indicates an unusual condition that is not necessarily an error. A sense operation is not required as a response to acceptance of a Unit Exception condition. Unit Exception is generated only while executing an I/O operation or performing an activity associated with an I/O operation and the condition is of immediate significance. Unit Exception indicates that no action is taken by the TU in response to a command.

Unit Exception is set when any of the following conditions occur.

- If Tape Indicate is on during a write, write tape mark (WTM), or erase gap operation. Unit Exception is set after a subsequent Write, WTM, or Erase Gap command if Tape Indicate is not reset.
- If a tape mark (TM) is sensed during a read, read backward, forward space block, or a backspace block operation. Unit Exception is set only for the TM read and is reset for any subsequent command.

4.4 SENSE BYTES

The sense bytes supplement the information contained in the status byte. A sense command transfers the sense bytes to the channel. The information contained in the sense bytes includes error and unusual conditions associated with the last operation and provides information about the current conditions present in the TCU and TU.

When reading through the sense bytes, reset indicates 0 and set indicates 1.

A summary of the sense bytes is given in Table 4-2.

Table 4-2. 4600 Sense Bytes

BYTE	BIT (HEX VALUE)							
	0 (8)	1 (4)	2 (2)	3 (1)	4 (8)	5 (4)	6 (2)	7 (1)
0	COMMAND REJECT ³	INTERVENE REQUIRED ³	BUS OUT CHECK ³	EQUIPMENT CHECK ³	DATA CHECK ³	OVERRUN ³	WORD COUNT ZERO ³	0
1	NOISE ²	TU STAT A	TU STAT B	0	BOT	WRITE STATUS	FILE PROTECT	NOT CAPABLE ³
2	TRACK-IN-ERROR (TIE)							
3	RAW VRC ²	MTE/LRC ²	SKEW ERROR ²	EDC/CRC ²	ENV/ECC ²	PE IN TU	BACKWARD STATUS	C/P COMPARE ²
4	MP HDW CHECK	REJECT TU ¹	TAPE INDICATE	WRITE VRC ²	0	LWR	TU CHECK	0
5 ¹	0	1	WTM CHECK ²	ID BURST CHECK ³	0	PARTIAL RECORD ²	POSTAMBLE ERROR ²	0
6	0	WRITE CHECK ¹	1	TU NOT IN PE	TU MODEL			
7	COLUMN OUT	FILE COL CHECK	MACHINE COL CHECK	RESET KEY	DSE CHECK	ERASE CHECK	0	LOAD CHECK
8	IBG DETECTED ²	0	0	0	0	0	0	0
9	8250 CORR	VELOCITY CHANGE ²	CHANNEL BUFFER CHECK	CRC III ²	1	0	0	TCU RESERVED
10	COMMAND STAT REJ ¹	0	0	REC NOT DETECTED ¹	0	TACH START FAILURE ¹	0	VELOCITY CHECK ¹
11	SPARE	CURRENT CHANNEL ⁵		CMD RTY ⁴	STORAGETEK MODEL			
12	32 K BUFFER FEATURE	3D TU	SPARE		CMD RTY CHL A	CMD RTY CHL B	CMD RTY CHL C	CMD RTY CHL D
13	TCU FEATURES		TCU SN (HIGH)					
14	TCU SN (LOW)							
15	TU SN (HIGH)							
16	TU SN (LOW)							
17	TWO CHNL SWITCH	COMMUNICATOR	TCU FEATURE	TCU FEATURE	TCU EC LEVEL			
18	0	0	0	0	TU EC LEVEL			
19	DEVICE END TU 7	DEVICE END TU 6	DEVICE END TU 5	DEVICE END TU 4	DEVICE END TU 3	DEVICE END TU 2	DEVICE END TU 1	DEVICE END TU 0
20	DEVICE END TU F	DEVICE END TU E	DEVICE END TU D	DEVICE END TU C	DEVICE END TU B	DEVICE END TU A	DEVICE END TU 9	DEVICE END TU 8
21	0	0	0	0	0	0	0	0
22	FAULT SYMPTOM CODE (TCU ERROR)							
23	1	0	0	0	0	0	COR SUB	0

1. Sets Equipment Check
2. Sets Data Check
3. Sets Unit Check in Status Byte
4. Command Retry Capable
5. Current Channel: A = 00, B = 01, C = 10, D = 11

4.4.1 Sense Byte 0

Bit 0 Command Reject, is set when:

- A Write, WTM, or Erase command is issued to a file protected TU.
- An invalid command is received by the TCU.
- A Data Security Erase command is not chained to an Erase Gap command or is issued to a TU positioned at EOT.
- A Sense Reserve or Sense Release command is issued to a TCU that does not have two-channel switch capability or when a Sense Reserve or Sense Release command is issued other than as the first command in a chain.

Bit 1 Intervention Required, is set when the addressed TU is not ready or is nonexistent (not TU Status A).

Bit 2 Bus Out Check, is set when Bus Out has incorrect (even) parity during a command or data byte transfer.

Bit 3 Equipment Check, is set on a TCU operation when:

- Microprocessor Hardware Check (byte 4, bit 0) is set.
- Reject TU (byte 4, bit 1) is set.
- Command Status Reject (byte 10, bit 0), Record Not Detected (byte 10, bit 3), Tach Start Failure (byte 10, bit 5), or Velocity Check (byte 10, bit 7) is set.
- 25 ft of blank tape is encountered on a read in PE/NRZI or 15 ft of blank tape is encountered in GCR.
- Channel refuses command retry request by not indicating chaining.

Bit 4 Data Check, is set when:

- Noise (byte 1, bit 0) is set.
- R/W VRC (byte 3, bit 0), MTE/LRC (byte 3, bit 1), Skew Error (byte 3, bit 2), EDC/CRC (byte 3, bit 3), ENV/ECC (byte 3, bit 4) or C/P Compare (byte 3, bit 7) is set.
- Write VRC (byte 4, bit 3) is set.

- WTM Check (byte 5, bit 2) is set.
- In PE or GCR, Partial Record (byte 5, bit 5) is set or Postamble Error (byte 5, bit 6) detects an IBG too soon after end of data on a write operation.
- In PE or GCR, IBG Detected (byte 8, bit 0) is set.
- Velocity Change (byte 9, bit 1) is set. In PE or GCR, CRC III (byte 9, bit 3) is set.

Bit 5 Overrun, is set during a write operation when the channel cannot supply data to the TCU fast enough. Overrun during a write operation terminates the write operation and stops tape motion inhibiting further data requests to the channel. Overrun is set during a read or read backward operation when the channel cannot take data from the TCU fast enough. Overrun during a read operation terminates data transfer but allows tape motion to continue until an IBG is detected. If Data Check is set, overrun is reset.

Bit 6 Word Count Zero, is set when Command Out responds to the first Service In of a write operation or when a "Stop" is received before data transfer occurs during a write operation.

Bit 7 Spare, always reset.

4.4.2 Sense Byte 1

Bit 0 Noise, is set when:

- Data is detected during an ERG or the erase portion of WTM.
- Creased tape is detected during a read or read backward operation.
- Data Check is set for a read or read backward operation.
- If overrun occurs followed by a Data Check during a write, read or read backward operation.
- In PE or GCR, if no data is transferred during a read or read backward operation and the block is not detected as a TM.

- In PE or GCR, when IBG is detected too late after end of data (long preamble) or too soon after end of data (short postamble) on a read command.

Bit 1 TU Status A and Bit 2, TU Status B. TU Status A is set when an addressed TU is selected, ready, and not busy. TU Status B is set when an addressed TU is rewinding, switched, or not ready. The bit definitions that follow indicate the status of the addressed TU.

Bit 1	Bit 2	Status
Reset (0)	Reset (0)	Nonexistent
Reset (0)	Set (1)	Not ready
Set (1)	Reset (0)	Ready and not rewinding
Set (1)	Set (1)	Ready and rewinding or switched

Bit 3 Spare, always reset.

Bit 4 BOT, is set when the selected TU is at BOT (load point).

Bit 5 Write Status, is set when the selected TU is conditioned to write.

Bit 6 File Protect, is set when the selected TU is conditioned not to write by the absence of a write enable ring.

Bit 7 Not Capable, is set when departing the load point (BOT) with a read or write command and the density configuration of the TU and TCU density capability are not compatible.

4.4.3 Sense Byte 2

Bits 0-7 Track-In-Error (TIE), are set for any track containing an error. In PE or GCR, TIE bits indicate dead tracks at the end of an operation. In NRZI, after a read operation, all reset indicates that Track P is in error; a single bit set with Data Check indicates the specific track in error; bits 6 and 7 set with Data Check indicates that the track-in-error cannot be found; and bits 6 and 7 set without Data Check indicates normal operation.

4.4.4 Sense Byte 3

- Bit 0 R/W VRC (Read/Write Vertical Redundancy Check), is set in PE or GCR when incorrect parity is detected in the read/write data path. R/W VRC is set in NRZI when a VRC occurred during a read operation or when a missing byte is detected.
- Bit 1 MTE/LRC (Multiple Track Error/Longitudinal Redundancy Check), is set in PE or GCR when multiple tracks are in error simultaneously during a read or write operation, or when Velocity Change (byte 9, bit 1) is set. MTE/LRC is set in NRZI when an LRC error occurs during a read or write operation.
- Bit 2 Skew Error, is set in GCR when excessive skew is detected during a read or write operation or when bit spacing within a byte is greater than 14 bit cell times. Skew Error is set in PE and GCR when a track fails to start. Skew Error is set in PE when skew between consecutive bits exceed three bits. Skew Error is set in NRZI when excessive skew is detected during a write operation.
- Bit 3 EDC/CRC (End Data Check/Cyclic Redundancy Check), is set in PE or GCR when CRC III (byte 9, bit 3) is set. EDC/CRC is set in NRZI when a CRC Register error occurs during a read or write operation.
- Bit 4 ENV/ECC (Envelope/Error Correction Check), ENV/ECC is set when there is insufficient data amplitude on a read or write operation. ENV/ECC is set in PE or GCR when no end of data occurs in a LWR operation, when an IBG is not detected during a write operation, or when WTM Check (byte 5, bit 2) is set. ENV/ECC is set in NRZI when a byte with incorrect parity is detected during a write operation.
- Bit 5 PE in TU, is set when the TU is in PE mode (1600 bpi).
- Bit 6 Backward Status, is set when the TU is in backward status.
- Bit 7 C/P Compare, is set in PE and GCR when the hardware detects an internal parity error.

4.4.5 Sense Byte 4

Bit 0 Microprocessor Hardware Check, is set to indicate a hardware error in the channel area. Subsystems with data streaming capability do not use this bit.

Bit 1 Reject TU, in set when:

- The selected TU drops Ready during a tape motion command.
- A change in read status occurs.
- Command Status Reject (byte 10, bit 0) is set.
- Tach Start Failure (byte 10, bit 5) is set.
- Write Inhibit is not active when Go is set.
- Velocity Check (byte 10, bit 7) is set.
- No IBG is found after the GCR or PE ID burst.

Bit 2 Tape Indicate, is set when the EOT marker is sensed during a forward tape motion.

Bit 3 Write VRC, is set in PE or GCR when data has incorrect parity during data transfer to the TU.

Bit 4 Spare, always reset.

Bit 5 LWR, is set when the last command was Loop Write-To-Read.

Bit 6 TU Check, is set to indicate TU failures such as write or erase head failures.

Bit 7 Spare, always reset.

4.4.6 Sense Byte 5

Bit 0 Spare, always reset.

New Subsystem, identifies the 4600 Tape Subsystem and is always set.

Bit 2 WTM Check, is set when a TM is not written properly.

Bit 3 ID Burst Check, is set in PE or GCR when an identification burst is not written correctly from BOT. ID Burst Check may be set in GCR when the ID burst is recognized but the ARA is not during a read operation.

Bit 4 is not used; always reset.

Bit 5 Partial Record, is set in PE or GCR when an IBG appears before end of data is recognized.

Bit 6 Postamble Error, is set when the IBG is not detected during the allowable time limits after end of data is recognized for a read or write operation.

Bit 7 Spare, always reset.

4.4.7 Sense Byte 6

Bit 0 Spare, always reset.

Bit 1 Write Check, is set when erase head current is flowing while the TU is in read status.

Bit 2 DD TU (Dual Density TU), is always set, indicating that the addressed TU is capable of both GCR and PE operation.

Bit 3 TU Not in PE, is set to indicate that the addressed TU is in either GCR or NRZI mode.

Bit 4 TU Density, defines the density of the addressed TU. Set indicates that the TU is set in PE or GCR; reset indicates that the tape unit is set to NRZI.

Bits 5-7 TU Speed, define the tape speed of the addressed TU as indicated below:

Speed	Bit 5	Bit 6	Bit 7
125 ips	Set (1)	Reset (0)	Reset (0)
200 ips	Set (1)	Reset (0)	Set (1)

4.4.8 Sense Byte 7

- Bit 0 Column Out, is set when tape in either vacuum column bottoms out or pulls out of the column. Column Out can be reset with the RESET switch.
- Bit 1 File Column Check, is set when the tape loop in the file reel vacuum column extends beyond acceptable limits.
- Bit 2 Machine Column Check, is set when the tape loop in the machine reel vacuum column extends beyond acceptable limits.
- Bit 3 Reset Key, is set when the RESET switch was actuated some time after Go was sent to the drive (Drive off Load Point).
- Bit 4 DSE Check, is set when a failure occurs during a Data Security Erase operation.
- Bit 5 Erase Check, is set when erase head current is not present during write status or when erase head current is present during read status.
- Bit 6 Spare, always reset.
- Bit 7 Load Check, is set when the TU fails to load properly.

4.4.9 Sense Byte 8

- Bit 0 IBG Detected, is set when an interblock gap (IBG) is detected while writing a record.
- Bits 1-7 Spare, always reset.

4.4.10 Sense Byte 9

- Bit 0 6250 Correction, is set when a one or two-track correction was attempted during a GCR read or write operation. This bit is set for information only and does not indicate an error.
- Bit 1 Velocity Change, is set when an excessive velocity change is detected during a write operation.
- Bit 2 Channel Buffer Check, is set when data sent in to the channel buffer does not match data sent out of the channel buffer.

- Bit 3 CRC III, is set when a CRC error is detected for a read or write operation or when incorrect data is transferred through a portion of the read/write path during a read or write operation.
- Bit 4 6250, is always set, indicating that the TCU has the capability of writing and reading GCR data (6250 bpi).
- Bits 5 and 6 Spare, always reset.
- Bit 7 TCU Reserved, is set when the TCU is in reserved status. This bit is set by a Sense Reserve command only with a TCU that has the two-channel switch option installed.

4.4.11 Sense Byte 10

- Bit 0 Command Status Reject, is set in GCR and NRZI when the TU fails to return the proper command status. Command Status Reject is set in PE when the TU has improper erase status.
- Bits 1 and 2 Spare, always reset.
- Bit 3 Record Not Detected, is set when a record can not be found during a write or WTM operation.
- Bit 4 Spare, always reset.
- Bit 5 Tach Start Failure, is set when the TU did not achieve proper velocity within an expected time period.
- Bit 6 Spare, always reset.
- Bit 7 Velocity Check, is set when the TU fails to attain proper velocity in the specified time period.

4.4.12 Sense Byte 11

- Bit 0 Spare, always reset.
- Bits 1 and 2, Current Channel, (A=00,B=01,C=10,D=11)
- Bit 3 Command Retry Capable, is set when the TCU is in record buffering mode (that is, the TCU can transfer data to and from the channel at channel speed).
- Bits 4-7 Model, define the subsystem model as shown below.

MODEL	Bit 4	Bit 5	Bit 6	Bit 7
3804	0	0	0	0
4500 STD	0	0	0	1
4500 BUFF	0	0	1	0
4600	0	0	1	1
4600 4 CH	0	1	0	0
4800	1	0	0	0
NEW PRODUCTS	1	1	X	X

4.4.13 Sense Byte 12

Bit 0, 32K Buffer, 32K buffer feature is installed when set.

Bit 1, 3D TU

Bits 2 and 3, Spare, always reset.

Bit 4, Command Retry, Channel A capable.

Bit 5, Command Retry, Channel B capable.

Bit 6, Command Retry, Channel C capable.

Bit 7, Command Retry, Channel D capable.

4.4.14 Sense Byte 13

Bits 0 and 1 TCU Features, identify TCU NRZI capability as defined below:

Bit 0	Bit 1	Feature
Reset (0)	Reset (0)	Not NRZI
Reset (0)	Set (1)	Reserved
Set (1)	Reset (0)	9-Track NRZI
Set (1)	Set (1)	Spare

Bits 2-7 TCU SN, provide the TCU serial number (high order).

4.4.15 Sense Byte 14

Bits 0-7 TCU SN, provide the TCU serial number (low order).

4.4.16 Sense Byte 15

Bits 0-7 TU SN, provide the TU serial number (high order).

4.4.17 Sense Byte 16

Bits 0-7 TU SN, provide the TU serial number (low order).

4.4.18 Sense Byte 17

Bit 0 Two Channel Switch, is set when the TCU contains two channel switch capability.

Bit 1 Communicator, is set when the TCU contains the communicator option.

Bit 2 Spare, always reset.

Bit 3, High Order 2x16, is set if high order TCU (and bit 1 is set) and reset for low order TCU.

Bits 4-7 TCU Level, reflect the diagnostic level of the TCU. Hex value is 1 for standard tape subsystems and 8 for tape subsystems with data streaming capability.

4.4.19 Sense Byte 18

Bits 0-3 Spare, always reset.

Bits 4-7 TU Level, reflect the diagnostic level of the TU.

4.4.20 Sense Byte 19

Bits 0-7 Device End, are set as follows:

Bit 0 - TU 7 Busy
Bit 1 - TU 6 Busy
Bit 2 - TU 5 Busy
Bit 3 - TU 4 Busy

Bit 4 - TU 3 Busy
Bit 5 - TU 2 Busy
Bit 6 - TU 1 Busy
Bit 7 - TU 0 Busy

4.4.21 Sense Byte 20

Bits 0-7 Device End, are set as follows:

Bit 0 - TU F Busy
Bit 1 - TU E Busy
Bit 2 - TU D Busy
Bit 3 - TU C Busy
Bit 4 - TU B Busy
Bit 5 - TU A Busy
Bit 6 - TU 9 Busy
Bit 7 - TU 8 Busy

4.4.22 Sense Byte 21

Not used; always reset.

4.4.23 Sense Byte 22

Bits 0-7 Fault Symptom Code, contains a two digit code used for fault isolation. Refer to the 4500/4600 Tape Subsystem Diagnostics Manual (PN 95574).

4.4.24 Sense Byte 23

Bits 0 and 6 Subsystem ID, identify the subsystem designation. For 4600 Tape Subsystems, bits 6 and 0 are set (82 hex). (Bits 1 through 5 and 7 are reserved.)

CHAPTER 5

DIAGNOSTICS

5.1 INTRODUCTION

The 4600 Tape Subsystem features an on-board diagnostics package. The diagnostics package is used to verify proper subsystem operation, verify engineering changes, diagnose subsystem and input-output (I/O) errors, aid in problem isolation, and verify repairs.

The diagnostic hardware includes the FE panel and a floppy disk drive. The software includes an IPL program contained in the IPL PROM and the 4600 Diagnostic Monitor program which resides on one floppy diskette and contains wake-up diagnostics and functional/reliability tests.

5.2 WAKE-UP DIAGNOSTICS

Wake-up diagnostics are performed automatically whenever the tape subsystem is powered on or whenever an IPL sequence is initiated from the FE panel.

The first group of wake-up tests is executed directly from the IPL PROM. These tests verify the RAM, parity error detection and the proper functioning of the floppy disk drive. The IPL PROM also contains a diskette loader program which loads the wake-up portion of the 4600 Diagnostic Monitor from the floppy diskette into the RAM. As these tests are loaded they are executed to verify the functional capability of the TCU. The FE panel displays a message to indicate the successful completion of these operations.

The TCU then downloads the TU microcode to each TU individually. When the TU downloading sequence is complete, the remainder of the 4600 Diagnostic Monitor is loaded from the floppy diskette, the TCU enters an idle loop, and the subsystem awaits further instruction from the channel (online or inline) or from the FE panel (inline or offline).

5.3 FUNCTIONAL/RELIABILITY TESTS

The functional/reliability routines are initiated at the FE panel. The majority of these routines are invoked as inline diagnostics, that is, they are executed while the subsystem is online and in use with only one TU offline. Inline diagnostics cannot execute the channel interface; this must be tested offline.

The first routines verify functional operation of the write path and read path in the TCU. Following functional verification, artificial stressing techniques are utilized to verify the error correction circuits: various types of flawed data are inserted and the output checked for proper error correction; excessively flawed data is also inserted to verify that the subsystem does not attempt correction on data that cannot be reliably corrected.

Subsequent routines perform loop write-to-read (LWR) testing, sample and analyze all TU Status Bytes, check all TU performance parameters, perform TU functional tests, and verify read/write reliability.

5.4 DETACHED DIAGNOSTICS

The 4600 Diagnostics Monitor also interfaces with a Storage Technology 3920 or 3925 Detached Diagnostic Device (DDD) through the FE panel maintenance port. The 3920/25 is a portable maintenance processor contained in a carrying case (approximate dimensions: 8x15x21 in; 30 lbs). The 3920/25 provides field engineering with a keyboard and Cathode Ray Tube (CRT) for two-way communication with the 4600 Diagnostic Monitor for enhanced diagnostic testing at the site or, through an acoustic coupler, over telephone lines to the Storage Technology Remote Maintenance Center (RMC) for remote diagnostics.

5.5 ERROR LOG

The 4600 Diagnostic Monitor also maintains an Error Log on the floppy diskette. The Error Log is a record of the number of online operations, the number of correctable errors, the number of uncorrectable errors and Unit Check status information. The Error Log stores these subsystem performance statistics at the completion of online operation and are accessed to aid in problem isolation or to measure tape subsystem performance.

CHAPTER 6

INSTALLATION PLANNING

6.1 INTRODUCTION

This chapter contains general guidelines for planning the installation of the 4600 Tape Subsystem. Information in this chapter is intended to briefly explain the requirements for subsystem layout and cabling. Some of the specifications are discussed in Chapter 2.

6.2 SUBSYSTEM LAYOUT

The physical layout of each subsystem depends on the amount of available space, the number of system components, and the customer's system application. A well-planned layout takes into consideration the following:

- operator access to equipment
- traffic flow
- material storage
- available power outlets
- machine gate and cover swing radii
- cable entry points
- service access (front and rear)
- fire hazards
- cooling and ventilation

6.3 SUBSYSTEM FLOORSPACE

The subsystem tape units (TUs) are usually installed in a linear configuration; however, by utilizing the optional corner assembly, the string can be shaped to include right angles (Figure 6-1) shows the space required for the individual A and B-units and for a complete eight-tape unit subsystem (linear configuration) and also illustrates the use of the corner

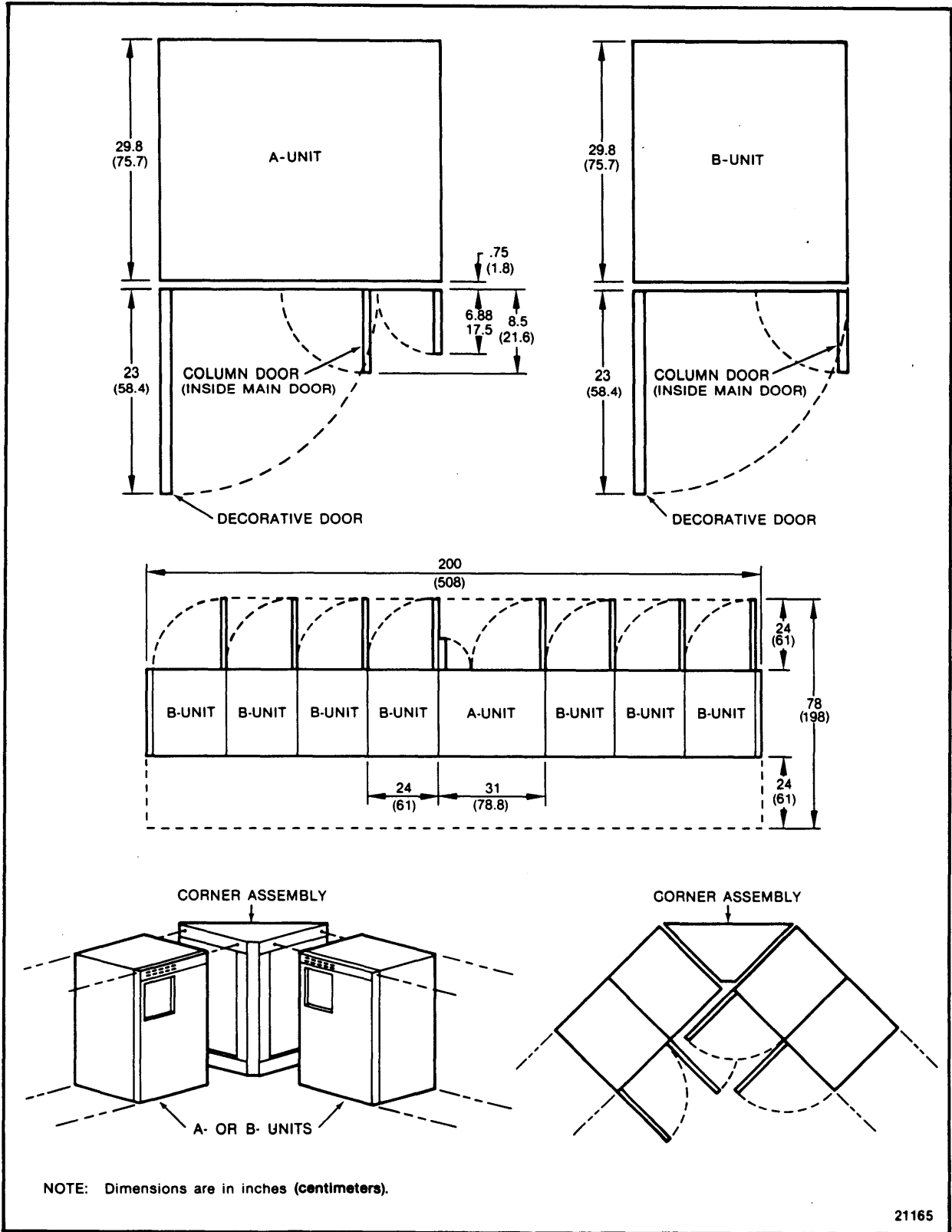

Figure 6-1. Floorspace Requirements

assembly. The units are shipped separately and the frames bolted together at the installation site. Two side covers, each 0.75 in (1.9 cm) thick, are shipped attached to the A-Unit and are, during installation, transferred to the exposed ends of the subsystem string.

The placement of the A-unit in the subsystem string is not critical except that, due to cabling restrictions, no more than four B-units are installed on either side of the A-unit. Marketing Conversion Order (MCO #68499) provides the capability of placing the 4600 A-unit at the head of a full 1 X 8 string.

Additional configuration flexibility is provided by the optional Corner Assembly (Figure 6-1). The Corner Assembly (MCO #68028) allows the 4600 string to be configured in an "L" shape.

6.4 CABLING

The four different types of external cabling supplied for the installation of the 4600 Tape Subsystem are listed in Table 6-1.

Table 6-1. External Subsystem Cable Types

Cable Type	Maximum Length	Number Required	StorageTek P/N
Channel Bus & Tag	See table 6-2	2 per channel	50030-XXX ³
EPO	No Limitation	1 per channel	50031-XXX ³
A-Unit Power ¹	15 ft (4.5 m)	1 per A-Unit	--NA-- ¹
Communicator ²	85 ft (25 m)	2 per feature	50033-XXX ³
¹ Supplied as part of A-Unit ² Required only when communicator feature is installed ³ XXX = Length of cable in ft			

6.4.1 A-Unit Power Cable

An external power cable is used to connect the A-unit power distribution assembly (PDA) to the facility's power source. Internal cables then connect from one PDA to the next PDA in the string. Raised floor access is not required to lay the cables.

The 60 Hz unit is provided with a shielded four-wire power cord: three phases and ground; 60 amps. The connector is a Russell and Stoll PN 7328 or equivalent. The compatible mating wall

connector is Russell and Stoll PN SC7324 and the compatible mating cable connector is Russell and Stoll PN SC7428. The mating connector is not supplied.

The 50 Hz unit is provided with a shielded four-wire power cord: three phases neutral, and ground; 40 amps. The 50 Hz units are shipped without a power connector.

6.4.2 Emergency Power Off (EPO) Cable

The EPO cable permits remote power control of the tape subsystem from the processor.

6.4.3 Channel Bus and Tag Cables

The channel bus and tag cables are the interface through which the TCU and channel exchange control and data signals. Refer to Table 6-2 for cable lengths. All lengths are given in feet, multiply by 0.3048 to determine meters.

6.4.4 Communicator Cables

The communicator feature requires two cables to transfer information between both subsystem TCUs, thus allowing either TCU to address any TU within the subsystem.

6.4.5 TCU-TU Interface Cables

The TCU to TU interface cables are internal to the tape subsystem. Raised floor access is not required to lay these cables. Each TU is radially connected to the TCU; daisy-chained connections are not permitted.

6.4.6 A-Unit Power Distribution Extension Cable

The optional Power Distribution Extension Cable permits the A-unit of a 1 X 8 subsystem to be placed at the head of string. This internal cable extends either power distribution bank of the A-unit permitting attachment of up to four B-units.

Table 6-2. Channel Cable Length Restrictions

System	Channel	Maximum Cable Length (FT) ¹	
		4650	4670
370/135-135	SEL	200	120
370/145-148	SEL	200	120
370/155-158	BLK MUX	200	103
370/165-168	2860 2880	200 200/350 ^{2, 3}	72 120/350 ^{2, 3}
370/195	2860 2880	200 200	72 120
4331-1	Not Supported		
4331-2 or 11	Data Streaming BLK MUX SEL	400 ⁴ 200/350 ^{2, 3, 5} 200/350 ^{2, 3}	400 ⁴ 120/350 ^{2, 3, 5} 120/350 ^{2, 3}
4341	Data Streaming BLK MUX SEL	400 200/350 ^{2, 3} 200/350 ^{2, 3}	400 120/350 ^{2, 3} 120/350 ^{2, 3}
303X	Data Streaming BLK MUX SEL	400 200/350 ^{2, 3} 200/350 ^{2, 3}	400 120/350 ^{2, 3} 120/350 ^{2, 3}
308X	Data Streaming BLK MUX SEL	400 200 200	400 120 120

¹ All measurements are given in feet. To determine meters, multiply by 0.3048.
² First value subsystems configured for std. interlock mode.
³ Restrictions observed for offset interlock mode follow:
A. Data chaining not supported regardless of cable length.
B. Must attach to 303X, 370/168, 4331-2, 11 or Amdahl V7-8.
1. 303X Director 1 limited to Channels 1,2, or 3.
2. 3032 and 3033 Director 2 limited to Channels 7,8, and 9.
3. 3033 Director 3 limited to block channel feature only.
4. 370/168 attachment limited to a 2880 channel.
C. TCU must be within 200-350 FT of cable from channel.
⁴ Model Group Two only with optional feature No. 1431.
⁵ Service-In only operation restricted to 30 feet.

(INTENTIONALLY LEFT BLANK)

APPENDIX A

GLOSSARY

The following glossary contains the terms and abbreviations (acronyms, symbols, and mnemonics) used in the 4600 Tape Subsystem Product Specification Manual.

-- A --

- A** Ampere, a unit of electrical current. One volt across one ohm of resistance causes a current flow of one ampere.
- ac** Alternating current.
- ANSI** American National Standards Institute.
- ARA Burst** Automatic Read Amplification Burst. A burst of all 1s data written in GCR recording at the beginning of the tape following the GCR ID burst. It is used by IBM to set read amplifiers. It is not used by StorageTek but is written to be compatible with IBM.

-- B --

- bit** Binary Digit. The smallest unit of information used in computer equipment. Being in the binary format, the number could be either 1 or 0.
- BOT** Beginning of Tape. The beginning of the permissible recording area.
- bpi** Bits per Inch. A term used when describing the recording density of a magnetic recording device. The maximum number of bits that can be recorded on the magnetic medium.
- BTU/hr** British Thermal Units per Hour.

-- C --

- cm** Centimeter.
- CRC** Cyclic Redundancy Check. A means of correction by which a failing byte and the bit within the byte can be determined in a record by mathematical and logical means.

CSA Canadian Standards Association.

-- D --

db Decibel. A unit that expresses the ration of two power levels on a logarithmic scale.

dc Direct Current.

DDD Detached Diagnostic Device. Refers to the StorageTek 3920 and 3925 diagnostic computers, which are used to run diagnostics, error log reports, and unit to unit (UUT) hook-up to the Remote Diagnostic Center, on various StorageTek products.

DSB Detail Sense Byte.

-- E --

ECC Error Correction Code (check). A code in which each expression conforms to specific rules of construction that also define one or more equivalent non-acceptable expressions and thus the error can be corrected.

EDC End Data Check.

EOT End of Tape. Detection of the reflective marker at the end of tape. Synonymous with Tape Indicate.

EPO Emergency Power Off. A line from the CPU to the CUs that will cause power to drop to all devices in the computer room if the EPO switch is activated.

-- F --

FCC Federal Communication Commission.

FE Field Engineer or Field Engineering.

FE Panel A control panel on the TCU that allows the FE to: power up, power down, test, and troubleshoot the TCU and attached equipment.

frpi Flux Reversals per Inch.

ft Foot.

-- G --

g Gram.

GCR Group Coded Recording. A tape recording mode that is written in the NRZI mode but never having more than two zeros together. This is accomplished by taking customer data 7 bytes at a time and converting it to 10 bytes to be written on tape. On a read operation the reverse process occurs and the original 7 bytes are returned.

GSB General Status Byte.

-- H --

Hz Hertz. A unit of frequency equal to one cycle per second.

-- I --

IBG Interblock gap. The erase area between blocks of data on magnetic tape.

ICA Interface Channel Adapter.

in Inch.

IPL Initial Program Load. The initialization procedure that causes an operating system to commence operation under its own control.

ips Inches per Second. A measure in tape speed. The number of inches of tape that can be moved past the read/write head in one second.

-- K --

kb/s Kilobytes per Second. A measure of data transfer between two units. One thousand bytes of data per second.

kg Kilogram.

KVA Kilovolt - Ampere.

-- L --

LB Pound.

LRC Longitudinal Redundancy Check. An error check that is made by generating a character and checking that character on a read back check or read. Each bit in the character is a result of the one bits in the

track. Every 1 bit in a record in each track compliments the bit in the LCR character. At the end of that record, the resulting state of that bit is written on tape.

-- M --

m Meter.

Mb/s Megabytes per Second. One million bytes per second.

μ s Microsecond. One millionth of a second.

mm Millimeter.

ms Millisecond. One thousandth of a second.

MTBF Mean Time Between Failures. A reliability characteristic of a device/system which, in conjunction with Mean Time To Repair (MTTR) is used to determine availability of that device/system to the user.

MTBM Mean Time Between Maintenance.

MTE Multi Track Error. Detection of more than one bad track (dead tracks or phase errors) on a PE read or write.

MTS Magnetic Tape Subsystem.

MTTR Mean Time to Repair. A factor in availability that measures the time to fix a failing device.

mv Millivolts.

-- N --

NRZI Non Return to Zero Indicated. A recording mode that only creates a flux change on tape if a one bit is to be written.

-- O --

OLTS Online Test System. A system that allows a user to test I/O devices concurrently with execution of programs. Tests may be run to diagnose I/O errors, verify repairs and ECs, or to periodically check devices.

oz Ounces.

-- P --

PDA Power Distribution Assembly.

PE Phase Encoded. A recording method by which all one bits cause flux changes in one direction and zero bits in the opposite direction. If two similar bits are written together, then a phase bit is written between them. This makes synchronzation of the tracks easier since a flux change is instructed for each bit written.

PF Power Factor.

PROM EC Programmable Read Only Memory Engineering Change.

psd Power Spectral Density.

-- R --

RDB Read Backward.

RDF Read Forward.

RMS Root Mean Square. The most common method of specifying the amount of a sine wave of voltage or current is by stating its value at 45°, which is 70.7 percent of the peak.

-- S --

Shoeshine A diagnostic routine that allows tape to move in the forward and backward direction at a high rate of speed.

-- T --

TCU Tape Control Unit.

TM Tape Mark. A specific byte pattern that is written on tape used to separate files. If a tape mark is detected on a read operation, unit exception will appear on the final status. If writing in 7 track NRZI, tracks 1, 2, 4, and 8 are used as a tape mark. If 9 track NRZI, then 6, 3, and 7 are written as a tape mark. If PE or GCR, then an absence of zone three constitutes a tape mark.

TU Tape Unit.

TUA Tape Unit Address.

-- U --

UL Underwriters' Laboratory.

-- V --

V Volts or Voltage.

Vac Volts of alternating current.

Vdc Volts of direct current.

VDE Verband Deutscher Electrotechniker.

VRC Vertical Redundancy Check.

-- W --

WTM Write Tape Mark. A TCU command that will cause the TU to erase a specific amount of tape then write a tape mark.

INDEX

A-Unit Power Cable	6-3	IDLE LOOP Indicator	3-9
A-Unit Power Distribution Extension Cable	6-4	Initial Program Load (IPL) Switch	3-7
Altitude	2-6	INLINE REQUEST Switch	3-7
		Installation Planning	6-1
Busy (bit 3)	4-3	INTRODUCTION v, 1-1, 2-1, 3-1, 4-1, 5-1, 6-1	
Cabling	6-3	LOAD/REWIND Switch	3-1
Channel Bus and Tag Cables	6-4		
Channel End (Bit 4)	4-4	MACH (Machine) RESET Switch	3-7
Channel Interface	4-1	MACHINE CHECK Indicator (Red)	3-4
Communicator Cables	6-4	Maintenance Port	3-11
Control Unit End (Bit 2)	4-3	Modes Of Data Transfer	4-1
Controls And Indicators	3-1		
Data Entry Keypad	3-10	OFFLINE Indicator	3-9
Data/Status Display	3-10	OFFLINE Indicator (Red)	3-4
Detached Diagnostics	5-2	OFFLINE REQUEST Switch	3-3
Device End (Bit 5)	4-4	Operator Control Panel	3-1
Diagnostics	5-1	Optional Features	1-8
Electrical Characteristics	2-3		
Emergency Power Off (EPO) Cable	6-4	Physical Dimensions	2-1
Enable/Disable Panel	3-5	Power Consumption	2-3
Environmental Requirements	2-5	Power Distribution And Control	2-4
Error Log	5-2	POWER ON Switch	3-7
Execute Keys	3-10	Primary Power	2-3
		Product Description	1-1
FE Panel	3-7	Product Specifications	2-1
Functional/Reliability Tests	5-2	Program Number Display	3-10
		Prompt Card Kit	3-10
General Description	1-1	READY Indicator (Green)	3-4
Glossary	A-1	Regulatory Agencies	2-5
		Relative Humidity	2-5
HEARTBEAT Indicator	3-9	REMOTE MAINT Indicator	3-9
Heat Dissipation	2-6	RESET Switch	3-3
		REWIND/UNLOAD Switch	3-3

INDEX CONT

SELECT Indicator (Amber)	3-4	Unit Check (Bit 6)	4-5
Selective Features	1-8	UNIT CHECK Indicator	3-9
Sense Byte 0	4-8	Unit Exception (Bit 7)	4-6
Sense Byte 1	4-9		
Sense Byte 10	4-15	Wake-Up Diagnostics	5-1
Sense Byte 11	4-15	WINDOW Switch	3-3
Sense Byte 12	4-16	WRITE DISABLED Indicator	
Sense Byte 13	4-16	(Red)	3-4
Sense Byte 14	4-17		
Sense Byte 15	4-17		
Sense Byte 16	4-17		
Sense Byte 17	4-17		
Sense Byte 18	4-17		
Sense Byte 19	4-17		
Sense Byte 2	4-10		
Sense Byte 20	4-18		
Sense Byte 21	4-18		
Sense Byte 22	4-18		
Sense Byte 23	4-18		
Sense Byte 3	4-11		
Sense Byte 4	4-12		
Sense Byte 5	4-12		
Sense Byte 6	4-13		
Sense Byte 7	4-14		
Sense Byte 8	4-14		
Sense Byte 9	4-14		
Sense Bytes	4-6		
Standard Features	1-7		
START Switch	3-1		
Status Information	4-2		
Status Modifier (Bit 1)	4-3		
Subsystem Description	1-4		
Subsystem Floorspace	6-1		
Subsystem Layout	6-1		
Tape Control Unit			
Description	1-4		
TAPE INDICATE Indicator			
(Amber)	3-4		
Tape Unit Description	1-5		
Tape Unit Maintenance			
Panel	3-11		
TCU-TU Interface Cables	6-4		
Temperature (Ambient Room			
Air)	2-5		

(INTENTIONALLY LEFT BLANK)

READER'S COMMENT FORM

Please check or fill in the items; adding explanations/comments in the space provided.

Which of the following terms best describes your job?

- | | | | |
|---|--|---|--|
| <input type="checkbox"/> Field Engineer | <input type="checkbox"/> Manager | <input type="checkbox"/> Programmer | <input type="checkbox"/> Systems Analyst |
| <input type="checkbox"/> Engineer | <input type="checkbox"/> Mathematician | <input type="checkbox"/> Sales Representative | <input type="checkbox"/> Systems Engineer |
| <input type="checkbox"/> Instructor | <input type="checkbox"/> Operator | <input type="checkbox"/> Student/Trainee | <input type="checkbox"/> Other (explain below) |

How did you use this publication?

- | | | | |
|--|---|-----------------------------------|--|
| <input type="checkbox"/> Introductory text | <input type="checkbox"/> Reference manual | <input type="checkbox"/> Student/ | <input type="checkbox"/> Instructor text |
| <input type="checkbox"/> Other (explain) _____ | | | |

Did you find the material easy to read and understand? Yes No (explain below)

Did you find the material organized for convenient use? Yes No (explain below)

Specific criticisms (explain below):

Clarifications on pages _____

Additions on pages _____

Deletions of pages _____

Errors on pages _____

Explanations and other comments:

Note: Staples can cause problems with automated mail sorting equipment. Please use pressure sensitive or other gummed tape to seal this form. If you would like a reply, please supply your name and address on the reverse side of this form.

Thank you for your cooperation. No postage stamp necessary if mailed in the U.S.A.

FOLD AND TAPE

DO NOT STAPLE

FOLD AND TAPE



NO POSTAGE
NECESSARY
IF MAILED
IN THE
UNITED STATES

BUSINESS REPLY CARD
FIRST CLASS PERMIT NO. 2 LOUISVILLE, CO U.S.A.

POSTAGE WILL BE PAID BY ADDRESSEE

Storage Technology Corporation
2270 South 88th Street
Louisville, Colorado 80028

Attn: Technical Publications MD 97

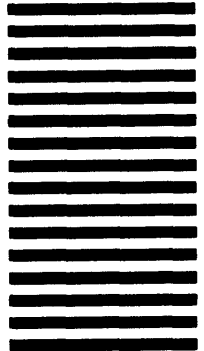

FOLD

DO NOT STAPLE

FOLD AND TAPE

If you would like a reply, please print:

Your Name: _____

Company Name: _____ Department: _____

Street Address: _____

City: _____

State: _____ Zip Code: _____

STORAGE TECHNOLOGY CORPORATION
2270 South 88th Street
Louisville, Colorado 80028